

conceptom

**advantages:**

multidisciplinary integration  
global collaboration  
projection design  
space expression and lighting  
rigorous planning executive  
technology study  
safety  
versatility

**services:**

utterer of the science  
art researchers  
emerging technologies  
architects  
industrial designers  
graphic designers  
writers  
animation  
filmmakers and videographers  
sound  
art and installation  
structural estimators  
engineering  
mechanical  
producers  
builders  
quality supervisors

**ventajas:**

integración multidisciplinaria  
colaboración global  
conceptualización a futuro  
comunicación museográfica y espacial  
planeación ejecutiva rigurosa  
estudio de tecnologías  
seguridad  
versatilidad

**servicios:**

divulgadores de la ciencia  
investigadores de arte  
tecnologías emergentes  
arquitectos  
diseñadores industriales  
diseñadores gráficos  
guionistas  
animación  
cineastas y videoastas  
sonorización  
instalación y arte  
calculistas estructurales  
ingenierías  
mecánica  
productores  
constructores  
supervisores de calidad

exhibiciones / exhibitions



corre**caballo**corre

Colecciones fotográficas de Fundación Televisa

Joseph Beuys, Manuel Álvarez Bravo, Gilbert & George, Víctor Casasola, Hernán Corona, Manuel Ramos, Gabriel Figueroa, are just a few of the photographers of this beautiful exhibition designed in 2004 for the XX *Festival de México en el Centro Histórico* in Mexico City.

The 6 slide projector installation made by Philip Glass's *Photographer* music and Manuel Álvarez Bravo's "Carrusel" image and the zoetrope's cylinders designed for the Muybridge images are both fantastic. But the most visited instalation of the show is the invisible horse that walks and runs over sand around a small ringmaster (based on Marey's studies).

Joseph Beuys, Manuel Álvarez Bravo, Gilbert & George, Víctor Casasola, Hernán Corona, Manuel Ramos, Gabriel Figueroa, son solo algunos de los fotógrafos de esta hermosa exhibición diseñada para el XX Festival de México en el Centro Histórico.

Se realizó una instalación a 6 proyectores hecha para "Carrusel" de Don Manuel Álvarez Bravo y la musica de Phillip Glass de "Photographer" y otra con zootropos cilíndricos de aluminio para las imágenes de los principios del cine, ambas increíbles, pero la más comentada fue nuestra pieza del caballo invisible que camina y corre sobre una arenosa pista de circo al centro de la sala, una mágica interpretación de los estudios de Marey y Muybridge.

Curaduría: Alfonso Morales  
Colección: Fundación Televisa

## Corre caballo corre

Antiguo Colegio de San Ildefonso, Ciudad de México, 2004







# Corre caballo corre

Museo de Arte Contemporáneo MARCO, Monterrey, 2004



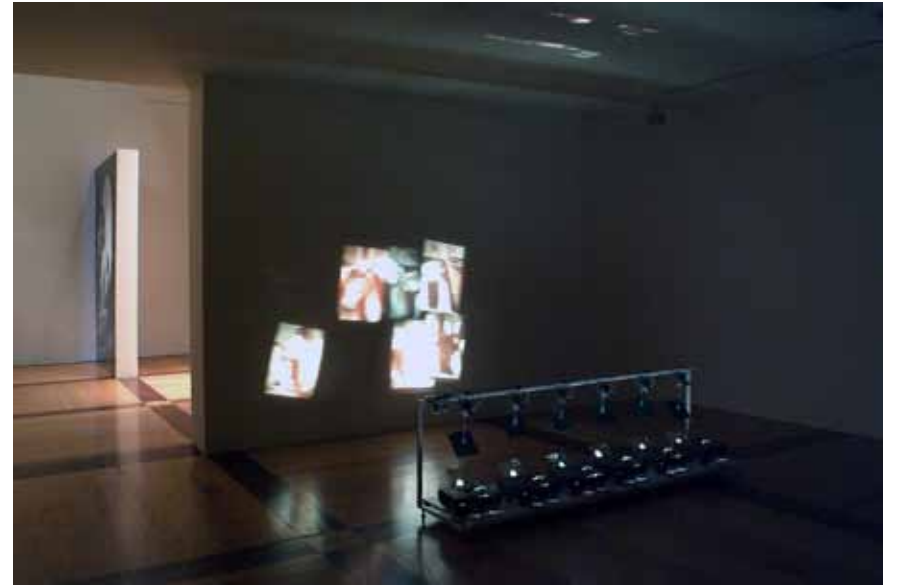









An impressive selection of images collected initially by Don Manuel Álvarez Bravo and now curated by Alfonso Morales for the Palacio de Bellas Artes in Mexico City. This unique experience of international photographers explains the difference in composition, movement, angle, rhythm; and the importance of photography in history itself.

Selección de obras fotográficas que alguna vez comenzó a coleccionar Don Manuel Álvarez Bravo y que ahora, bajo la curaduría de Alfonso Morales, se analizan particularidades de composición, ritmo, perspectiva y la magia particular de diferentes generaciones. Revela por supuesto, la importancia de este registro artístico e histórico sin igual.

Colección: Fundación Televisa  
Curaduría: Alfonso Morales

# Eternidad fugitiva

Palacio de Bellas Artes, Ciudad de México, 2004











# El murmullo de los rostros, Paul Strand

Palacio de Bellas Artes, Ciudad de México, 2011

Un total de 220 obras originales del artista norteamericano Paul Strand (1890-1976), considerado el iniciador de la modernidad fotográfica y democratizador de los temas de la fotografía, la muestra retrospectiva incluye fotografías, proyecciones videográficas, carteles y documentos que el artista obtuvo en su paso por México.

The American artist Paul Strand (1890-1976) is considered one of the pillars of modern photography and a democratic visionary in this practice. The exhibition presents more than 220 original masterpieces recently acquired from the Smithsonian Institute in NY by Fundación Televisa. Photos, cinema, posters and unique documents created by this great artist in his journey through Mexico.

Curaduría: Alfonso Morales  
Colección: Fundación Televisa





PAUL  
STRAND

Chicago Art

Chicago Art  
Chicago Art  
Chicago Art











1910



¿Dónde están Ella, Kate, Mag, Lizzie y Edith,  
la de corazón sensible, la de alma simple, la vocinglera,  
la orgullosa, la feliz?  
Todas, todas están durmiendo en la colina.



La exhibición celebra los logros y herencias del cinefotógrafo mexicano Gabriel Figueroa (1907-1997), un profundo personaje que influenció y construyó una imagen que prevalece como parte del México moderno. Forjó una identidad cultural en conjunto con una poderosa generación de artistas e intelectuales nacionales, norteamericanos y europeos, que aún resuena fuertemente en la audiencia internacional.

The exhibition celebrates the achievements and legacy of Mexican cinematographer Gabriel Figueroa (1907-1997), a profoundly influential figure who built an enduring image of Mexico through his visual style. Figueroa forged a vision of Mexican identity and culture that resonated powerfully with Mexican and international audiences.

Curaduría: Alfonso Morales  
Co-curadores: Britt Salvesen y Rita González  
Colección: Fundación Televisa

# Under the Mexican Sky Gabriel Figueroa

Los Angeles County Museum of Art, Los Ángeles, California, 2014

















ars suddenly



# La traversée d'un regard Gabriel Figueroa

Arles, Francia, 2011

Exposición retrospectiva de Gabriel Figueroa  
Curaduría: Alfonso Morales  
Colección: Fundación Televisa















# Gabriel Figueroa, cinefotógrafo

Palacio de Bellas Artes, Ciudad de México, 2007

Exposición retrospectiva de Gabriel Figueroa  
Curaduría: Alfonso Morales  
Colección: Fundación Televisa













Small rectangular label below the first photograph.



Small rectangular label below the second photograph.



Small rectangular label below the third photograph.







## Metropolit

Il metropolitano è un mezzo di trasporto pubblico che si muove su rotaie e che è gestito da una società pubblica o privata. È un mezzo di trasporto che si muove su rotaie e che è gestito da una società pubblica o privata. È un mezzo di trasporto che si muove su rotaie e che è gestito da una società pubblica o privata.

Il metropolitano è un mezzo di trasporto pubblico che si muove su rotaie e che è gestito da una società pubblica o privata. È un mezzo di trasporto che si muove su rotaie e che è gestito da una società pubblica o privata. È un mezzo di trasporto che si muove su rotaie e che è gestito da una società pubblica o privata.

Il metropolitano è un mezzo di trasporto pubblico che si muove su rotaie e che è gestito da una società pubblica o privata. È un mezzo di trasporto che si muove su rotaie e che è gestito da una società pubblica o privata. È un mezzo di trasporto che si muove su rotaie e che è gestito da una società pubblica o privata.





# Gabriel Figueroa, cinefotógrafo

Centro Cultural Tijuana CECUT, Baja California, 2009

Exposición retrospectiva de Gabriel Figueroa  
Curaduría: Alfonso Morales  
Colección: Fundación Televisa



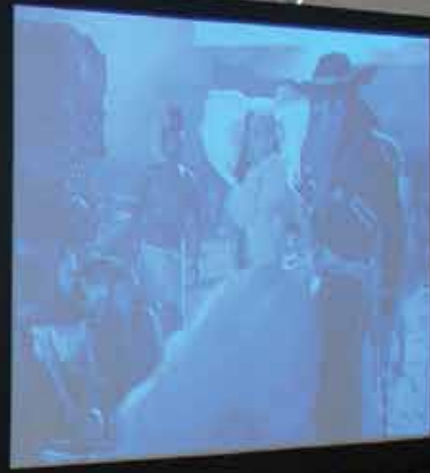









# Gabriel Figueroa, cinefotógrafo

Nave Lewis Parque Fundidora, Monterrey, Nuevo León, 2009

Exposición retrospectiva de Gabriel Figueroa  
Curaduría: Alfonso Morales  
Colección: Fundación Televisa









Several lines of text are displayed on the wall, providing information about the exhibit.













# Gabriel Figueroa, cinefotógrafo

Museo de Arte de Zapopan, Guadalajara, Jalisco, 2010

Exposición retrospectiva de Gabriel Figueroa  
Curaduría: Alfonso Morales  
Colección: Fundación Televisa









# Adorable y enemiga, Abel Quezada

Rejas de Chapultepec, Ciudad de México, 2009







**Responsabilità  
di tutti i bambini**

Il mondo è un luogo meraviglioso e pieno di opportunità. Ma per poterlo vivere al meglio, abbiamo bisogno di tutti. Di tutti i bambini. Di tutti i ragazzi. Di tutti gli adulti. Di tutti gli animali. Di tutti gli esseri viventi. Di tutti gli esseri senzienti. Di tutti gli esseri che hanno il diritto di essere rispettati e amati. Di tutti gli esseri che hanno il diritto di vivere in un mondo libero, pacifico e giusto. Di tutti gli esseri che hanno il diritto di essere ascoltati e di far sentire la loro voce. Di tutti gli esseri che hanno il diritto di essere considerati come individui e non come numeri. Di tutti gli esseri che hanno il diritto di essere trattati con dignità e rispetto. Di tutti gli esseri che hanno il diritto di essere considerati come parte di una comunità e non come estranei. Di tutti gli esseri che hanno il diritto di essere considerati come esseri umani e non come oggetti. Di tutti gli esseri che hanno il diritto di essere considerati come esseri liberi e non come schiavi. Di tutti gli esseri che hanno il diritto di essere considerati come esseri creati a immagine e somiglianza di Dio e non come esseri creati solo per essere sfruttati. Di tutti gli esseri che hanno il diritto di essere considerati come esseri che meritano di essere amati e rispettati. Di tutti gli esseri che hanno il diritto di essere considerati come esseri che meritano di essere considerati come parte di una comunità e non come estranei. Di tutti gli esseri che hanno il diritto di essere considerati come esseri che meritano di essere considerati come parte di una comunità e non come estranei.

**Il tuo diritto**

Il tuo diritto è di essere rispettato e amato. Il tuo diritto è di vivere in un mondo libero, pacifico e giusto. Il tuo diritto è di essere ascoltato e di far sentire la tua voce. Il tuo diritto è di essere considerato come individuo e non come numero. Il tuo diritto è di essere trattato con dignità e rispetto. Il tuo diritto è di essere considerato come parte di una comunità e non come estraneo. Il tuo diritto è di essere considerato come essere umano e non come oggetto. Il tuo diritto è di essere considerato come essere libero e non come schiavo. Il tuo diritto è di essere considerato come essere creato a immagine e somiglianza di Dio e non come essere creato solo per essere sfruttato. Il tuo diritto è di essere considerato come essere che meritano di essere amati e rispettati. Il tuo diritto è di essere considerato come essere che meritano di essere considerati come parte di una comunità e non come estraneo. Il tuo diritto è di essere considerato come essere che meritano di essere considerati come parte di una comunità e non come estraneo.

**Il tuo diritto**

Il tuo diritto è di essere rispettato e amato. Il tuo diritto è di vivere in un mondo libero, pacifico e giusto. Il tuo diritto è di essere ascoltato e di far sentire la tua voce. Il tuo diritto è di essere considerato come individuo e non come numero. Il tuo diritto è di essere trattato con dignità e rispetto. Il tuo diritto è di essere considerato come parte di una comunità e non come estraneo. Il tuo diritto è di essere considerato come essere umano e non come oggetto. Il tuo diritto è di essere considerato come essere libero e non come schiavo. Il tuo diritto è di essere considerato come essere creato a immagine e somiglianza di Dio e non come essere creato solo per essere sfruttato. Il tuo diritto è di essere considerato come essere che meritano di essere amati e rispettati. Il tuo diritto è di essere considerato come essere che meritano di essere considerati come parte di una comunità e non come estraneo. Il tuo diritto è di essere considerato come essere che meritano di essere considerati come parte di una comunità e non come estraneo.

Una exposición que viaja en un tiempo local, desde los campos productivos, las escuelas, los carnavales, los eventos sociales y políticos más controvertidos, todos registrados por el lente de una nueva generación de fotoperiodistas. *El privilegio de la memoria* es una travesía por una de las realidades más controvertidas y difíciles de nuestro México.

An exhibition that travels through local time. Young photo journalists take us through the productive rural lands and schools, to city carnivals and highclass social events, inside the political controversies of this region. We present a mosaic of talented cameras called *The Privilege of Memory*, a unique and complex vision in the current life of northern México.

Curaduría: Héctor Orozco

# El privilegio de la memoria

Galería de Arte Antonio López Sáenz, Culiacán, Sinaloa, 2013









# La Revolución Mexicana en el espejo de la caricatura estadounidense

Museo de Arte Carrillo Gil, Ciudad de México, 2010

Coordinación: Itala Schmelz  
Curaduría: Juan Manuel Aurrecoechea



El primer periódico de la historia de la prensa en España  
El primer periódico de la historia de la prensa en España  
El primer periódico de la historia de la prensa en España



11



12



11



15



16



17



18



19











Las experiencias compartidas por la investigadora en esta larga travesía de reflexiones entre el cielo y el cerro, inspiraron a crear un ambiente museográfico más acorde a todos estos crepúsculos, amaneceres y noches de astros, que en la intimidad de la fogata acompañaron sus ideas.

The analysis and studies shared by P.h.d Rossana Quiroz of her long and rigorous journey between the starry skies and prehispanic hills of San Miguel de Allende, have inspired us to create an intimate exhibit that vibrates with her years of observation between dusks and dawns, beside her fire camp in Cañada de la Virgen.

Investigación y curaduría:  
Dra. Rossana Quiroz  
Instituto Nacional de Antropología e Historia  
Cañada de la Virgen

# El cerro y el cielo

Centro Cultural Ignacio Ramírez “El Nigromante”,  
San Miguel de Allende, Guanajuato, 2010







museos / museums



Einstein opinaba que: "Una de las experiencias más hermosas que podemos vivir, es el misterio. La emoción fundamental que nace de la verdadera cuna del arte y la ciencia."

Explicando los conceptos más básicos del agua, procuramos plantear más fresca del discurso y sus instalaciones sin las complejas voces de la investigación. Hemos desarrollado un proyecto que trata de comunicar la divulgación a través de lo emocional, mostrando los conocimientos de la ciencia a través del arte.

Einstein once said: "One of the most beautiful experiences we can have, is the mysterious. It is the fundamental emotion which stands in the cradle of true art, and true science".

The Water Museum in Xochimilco, designed by TEN Arquitectos, is a carefully mixed combination between the science and technology museum and the contemporary art gallery. Since many art installations or visual commissions are carefully selected to local and foreign artist, the intellectual and emotional experience of the exhibit will have a fresh and creative proposal, that we believe is easy to understand. The basic concepts of water and its importance for life will be emotionally explained with new angles of presentation.

CIEAX Centro de Investigación y Estudios del Agua Xochimilco  
Arquitectura: TEN Arquitectos  
Investigación: Valente Souza  
Divulgación científica: Lucy Cruz  
Curaduría y museografía: Salvador Quiroz

# Museo del Agua (CIEAX)

Xochimilco, 2010

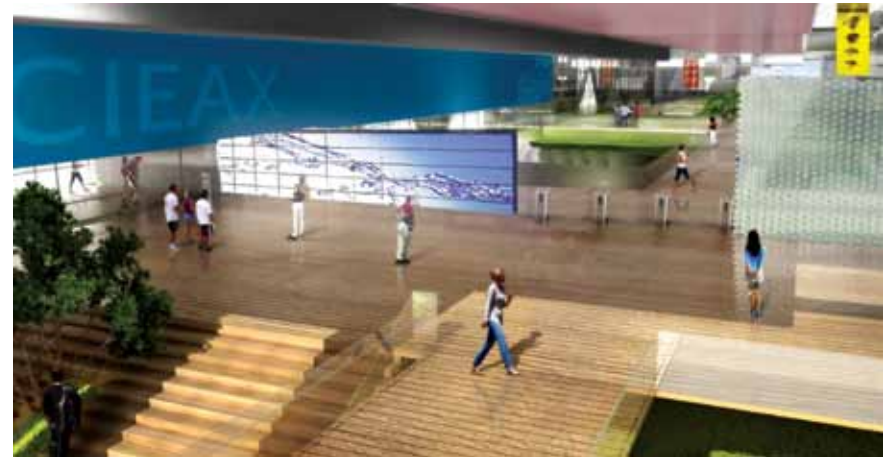



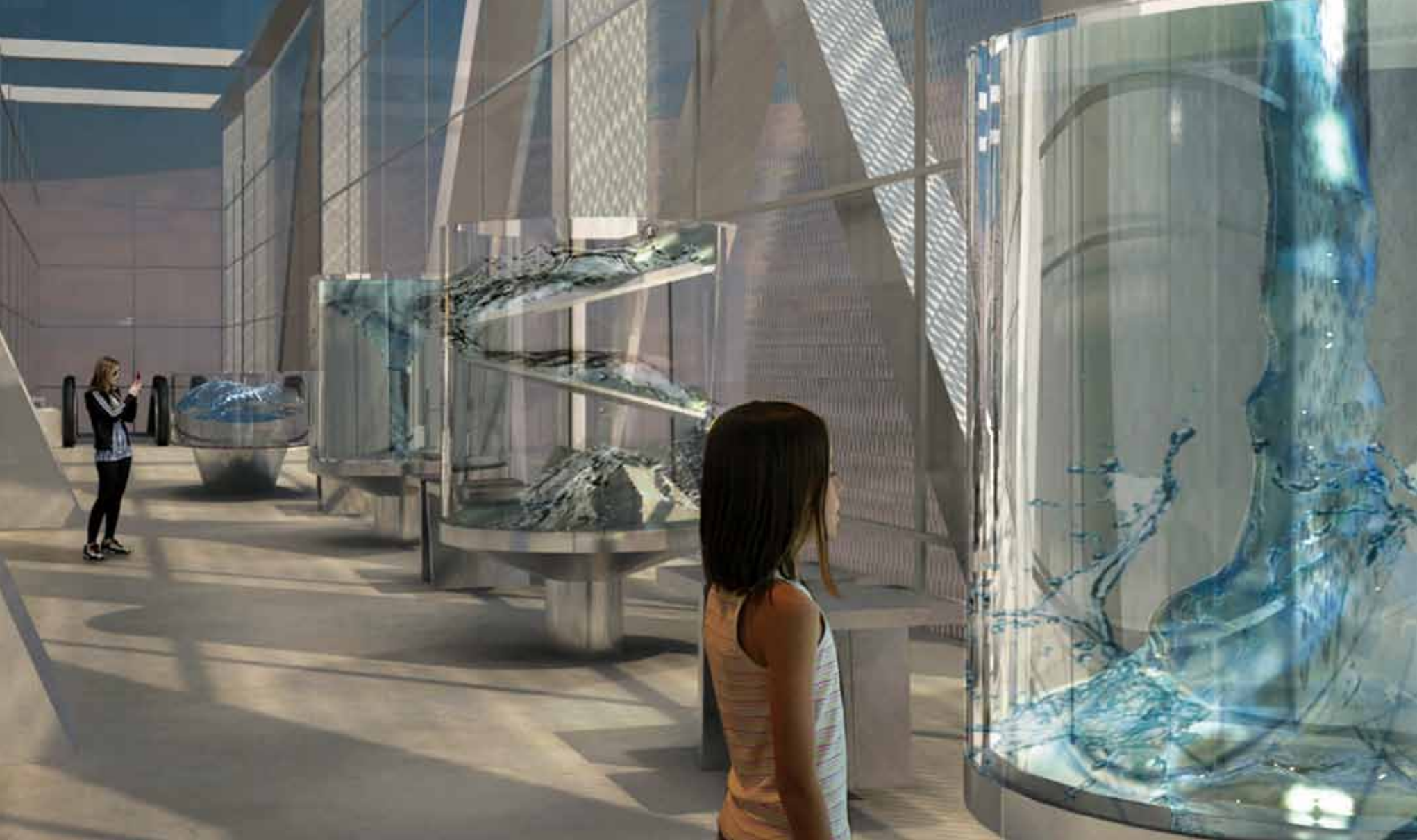





$H_2O$



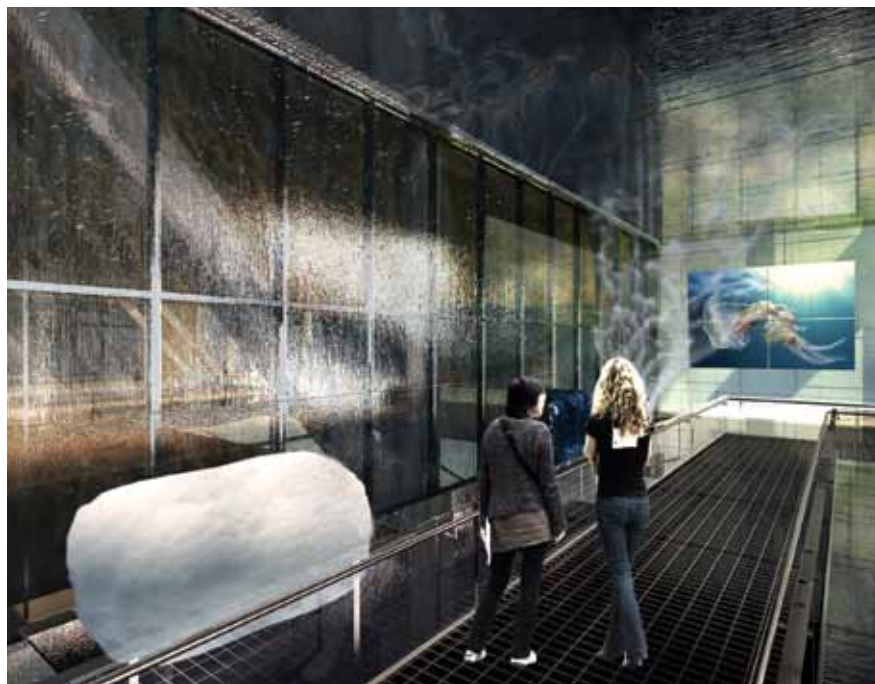





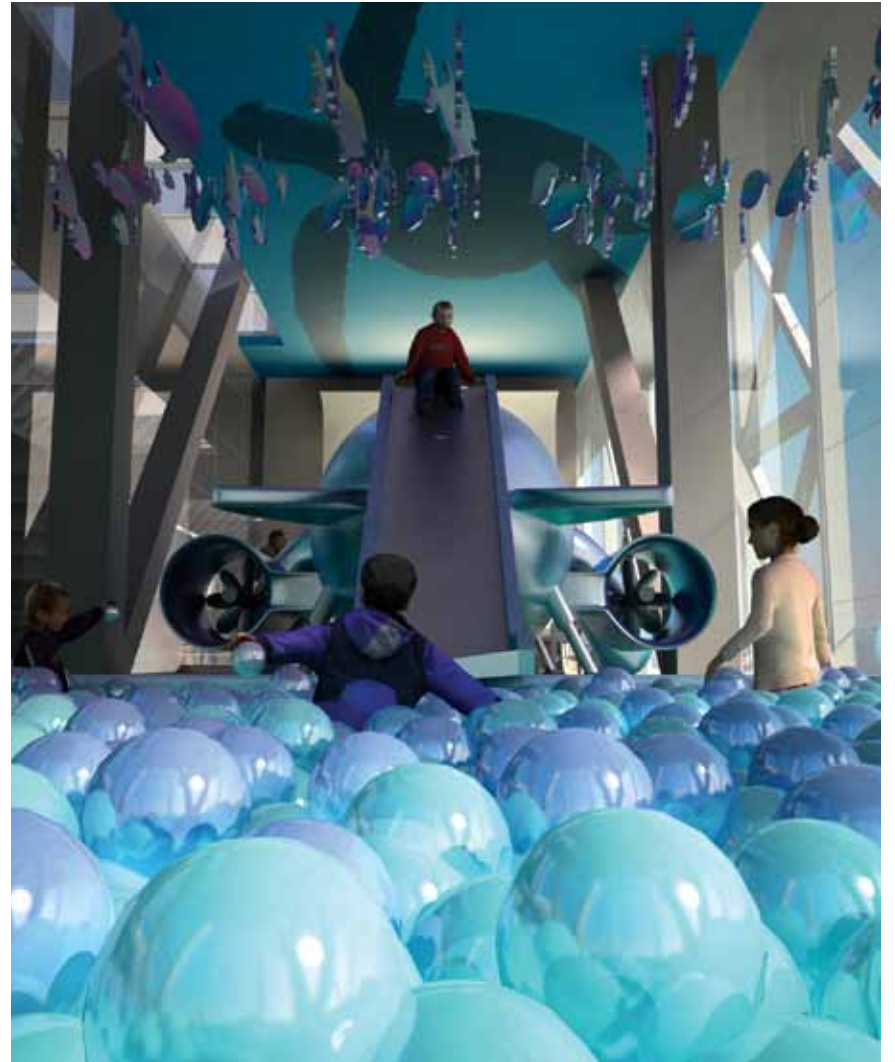



# Museo de la Biodiversidad

Cabo San Lucas, Baja California Sur, 2008

El Pabellón Cultural de la República es un intento de acercar más la cultura y las actividades educativas en el estado, así como mostrar la increíble biodiversidad que “el acuario del mundo” tiene que ofrecer. Baja California Sur es un lugar único, con más de 1000 especies endémicas.

The Pabellón Cultural de la República is an attempt to bring more culture and educational activities to the state, as well as show the incredible biodiversity that “the aquarium of the world” has to offer. Baja California Sur is a unique place with more than 1000 endemic species.

Primer lugar (concurso)

3,000 m<sup>2</sup>

Investigación: Dr. Exequiel Ezcurra

Arquitectura: Serrano-Monjaraz Arquitectos

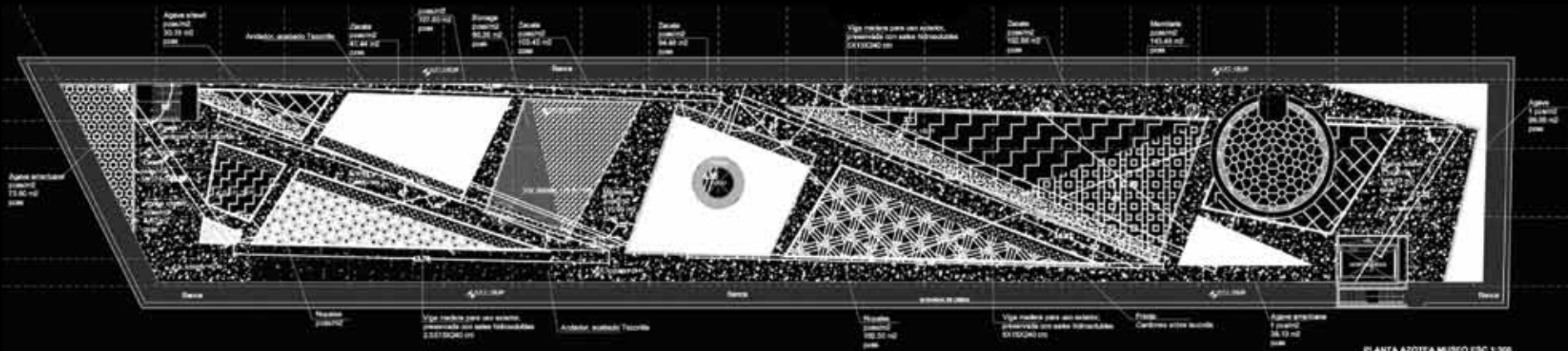
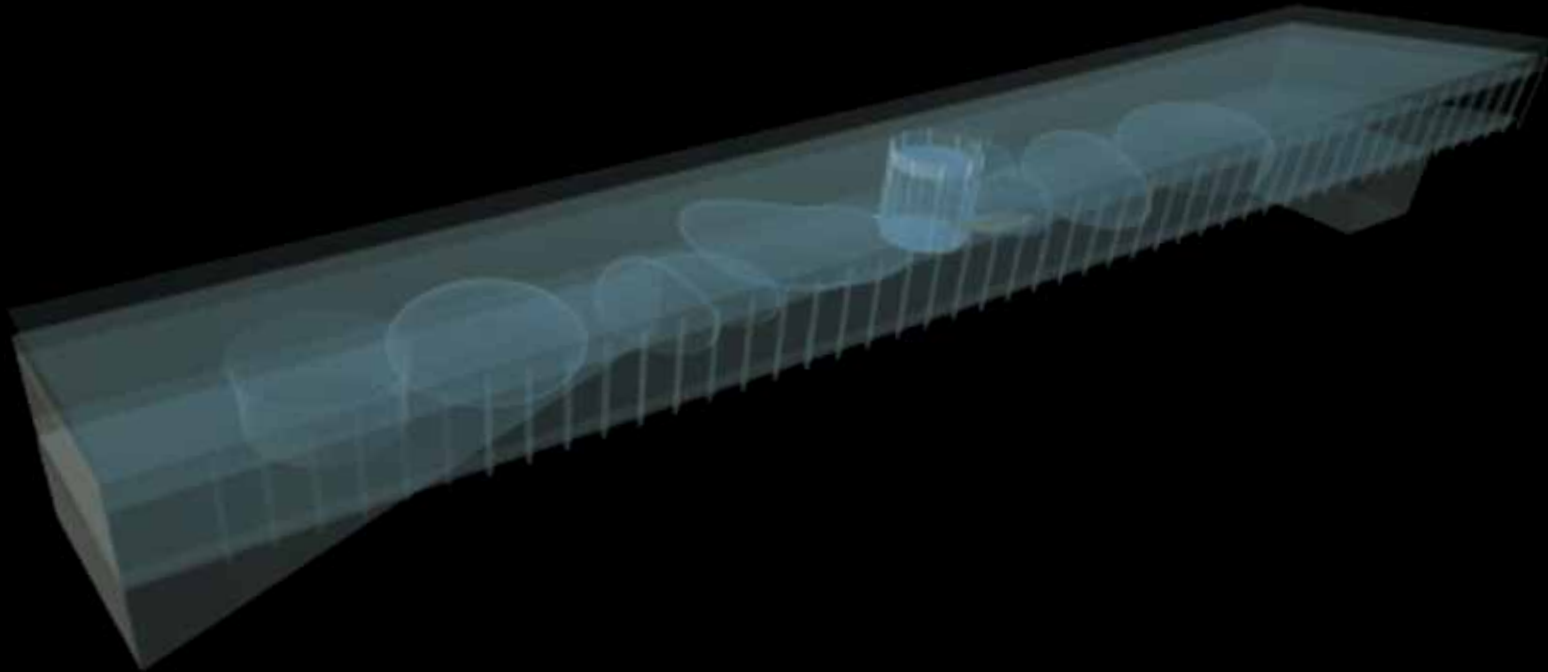

PLANTA AZOTEA MUSEO ESC 1:300

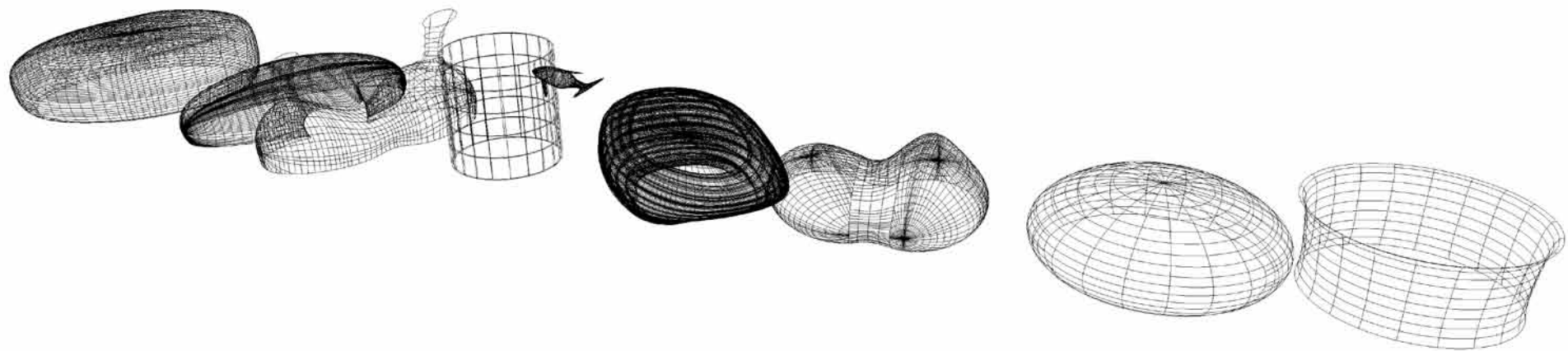
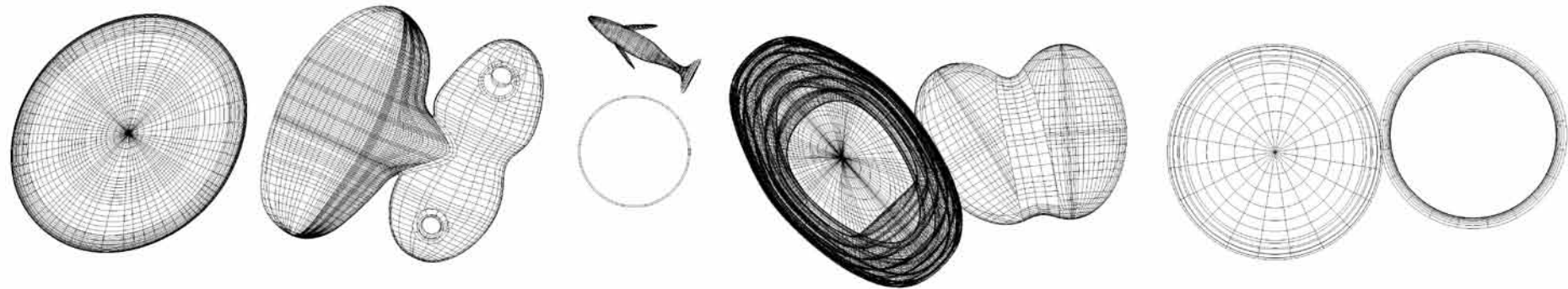

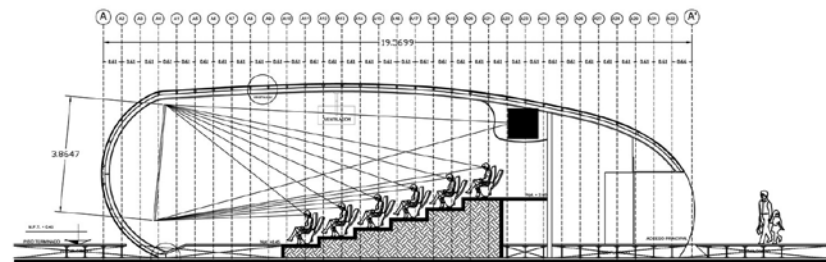

Corte Longitudinal  
ARQ-HPE-02

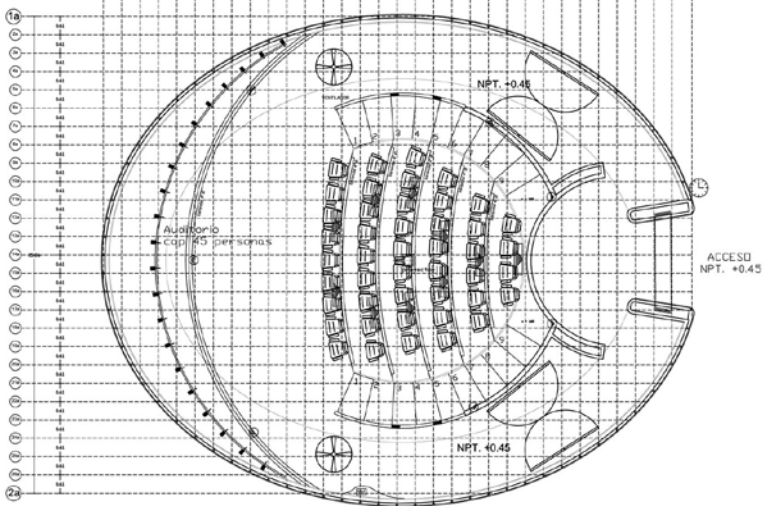

PLANTA ARQUITECTONICA  
ARQ-HPE-01

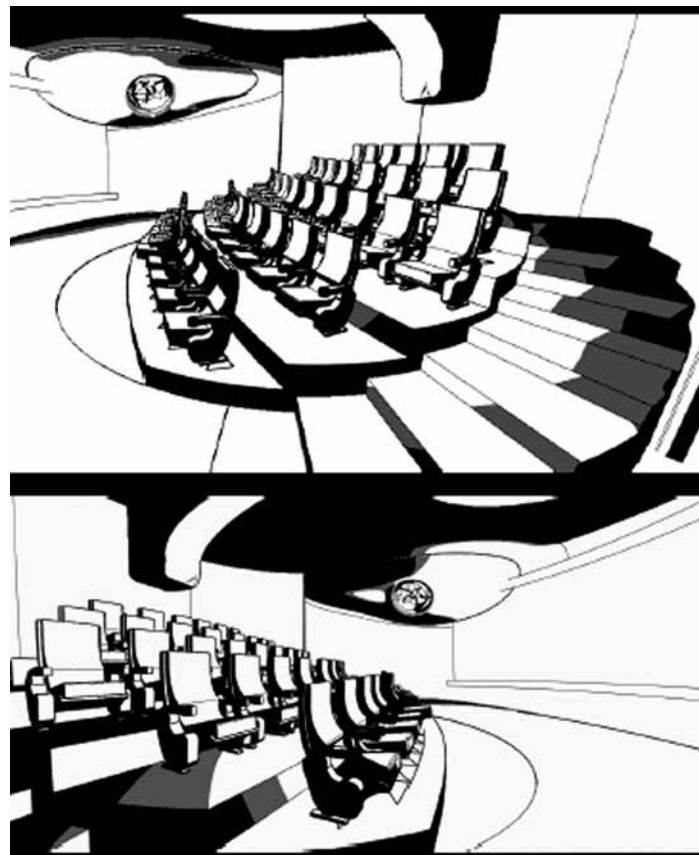

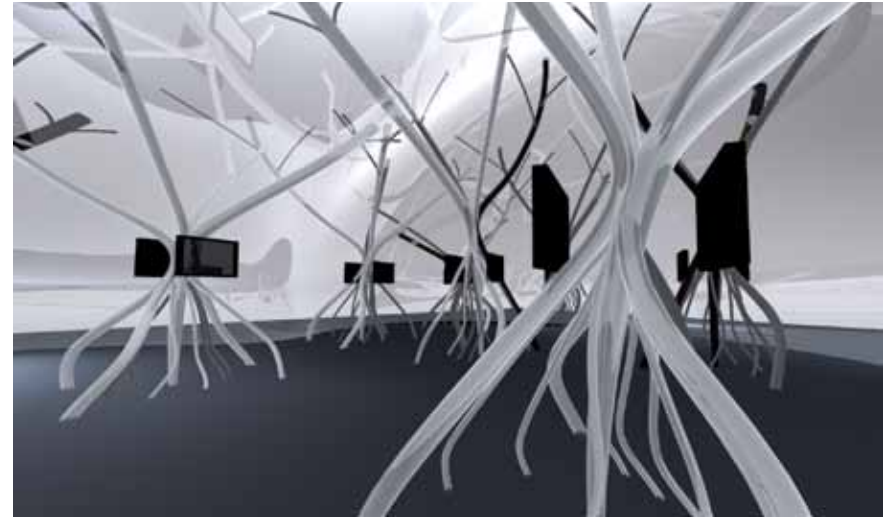
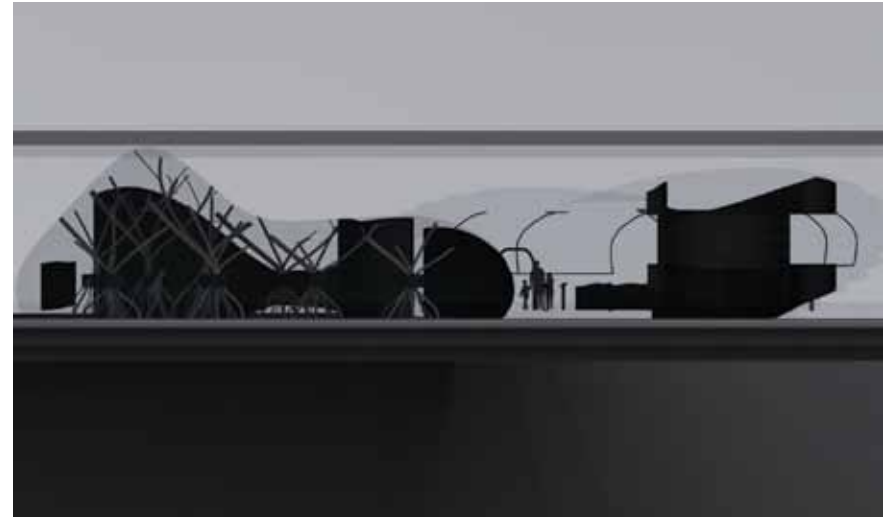
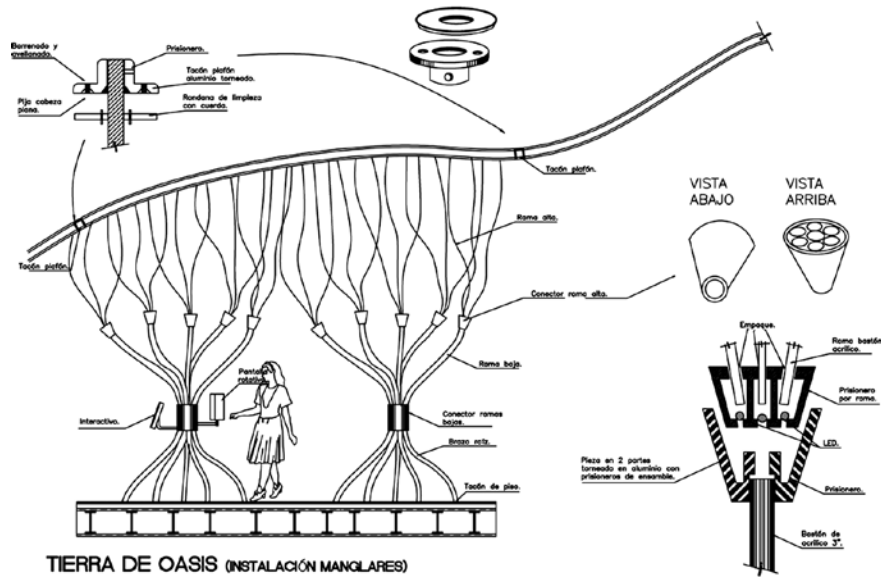

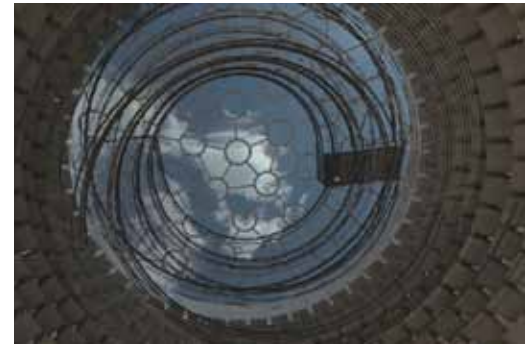
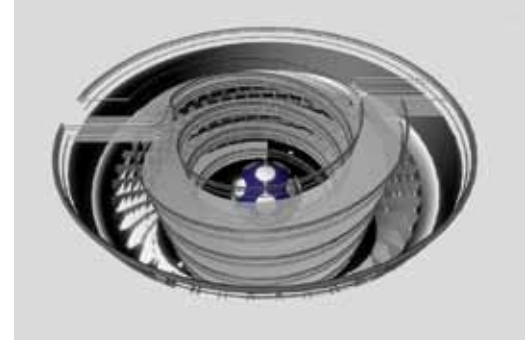
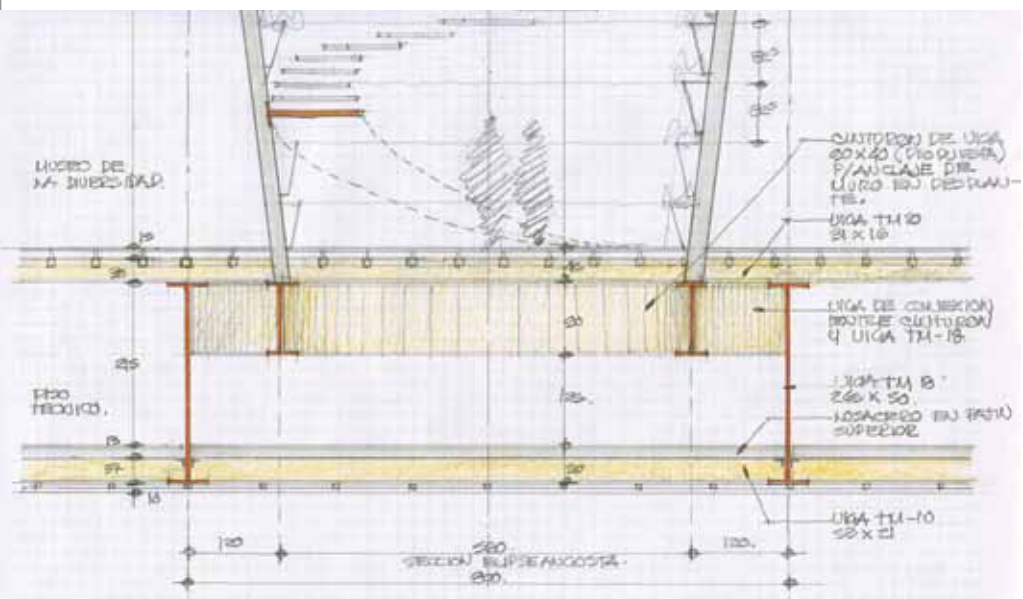
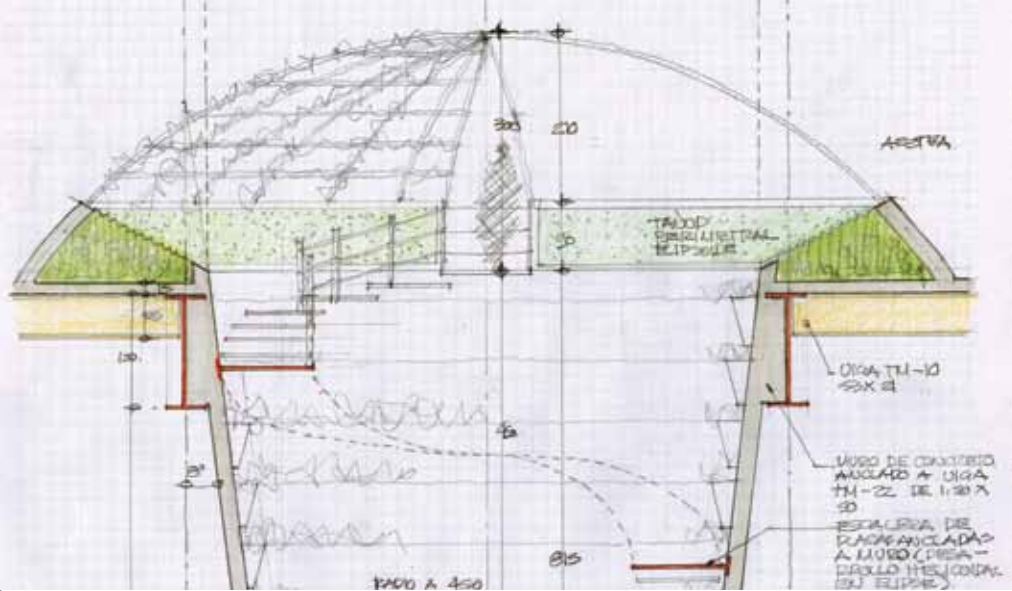



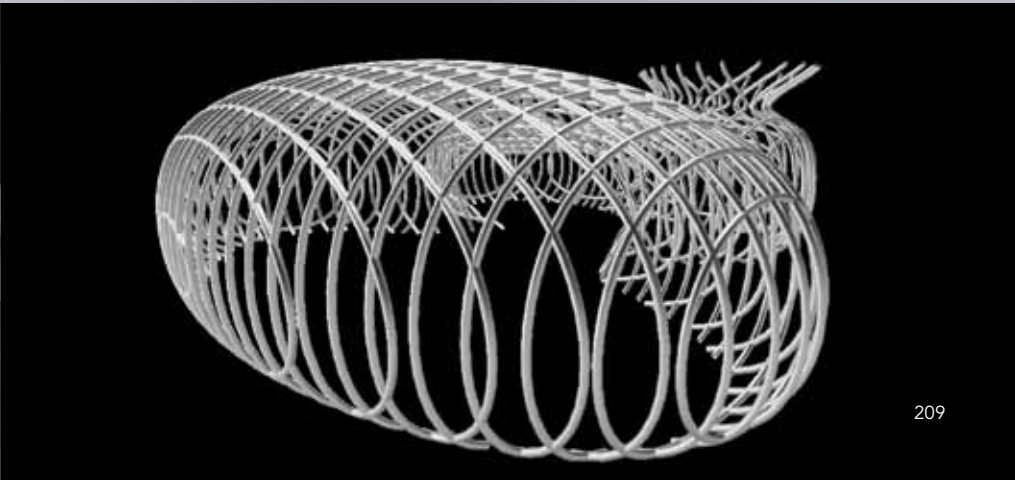
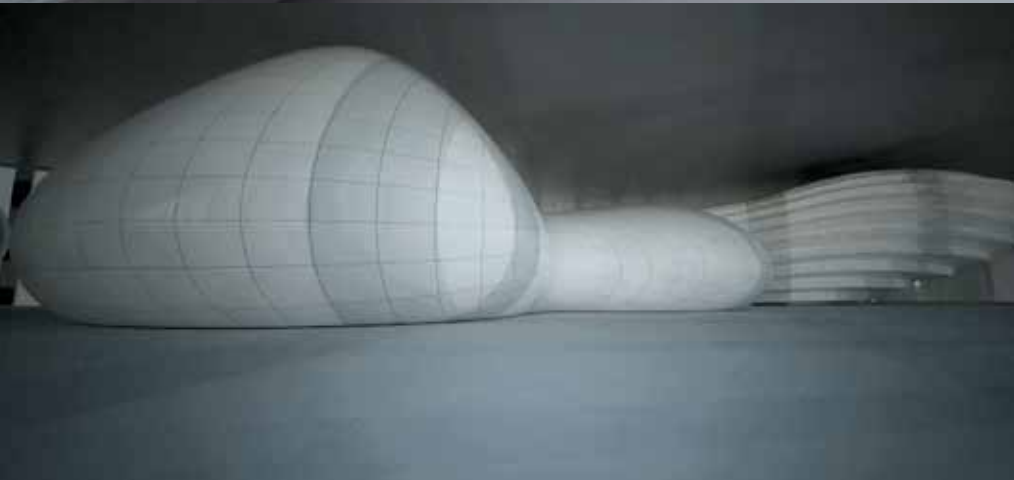
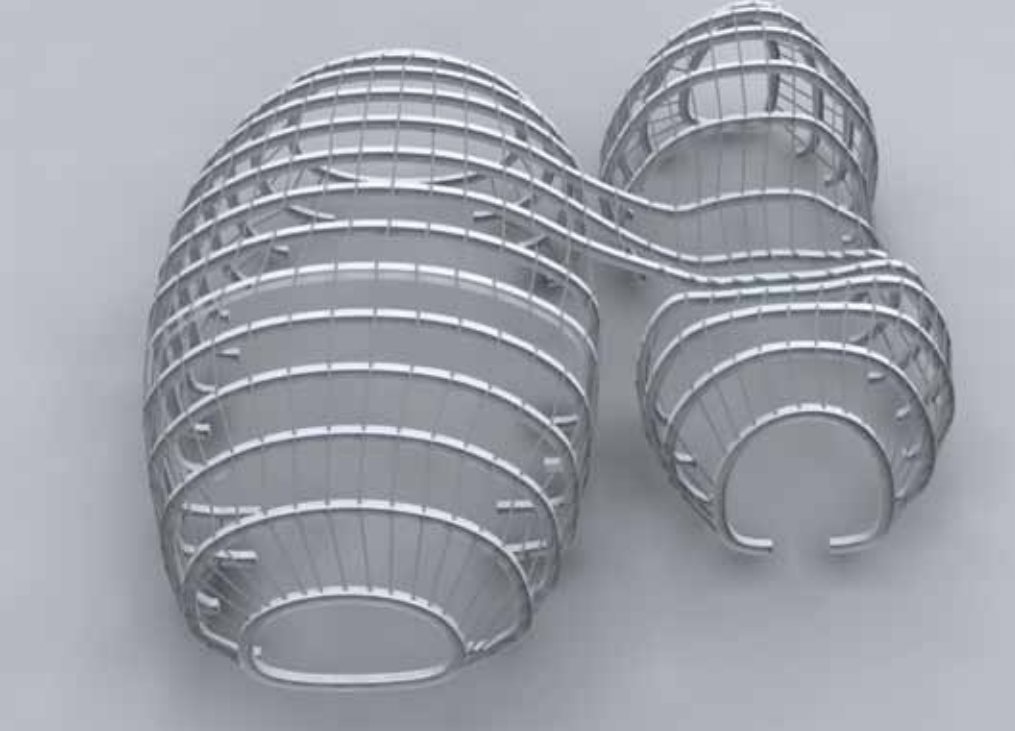
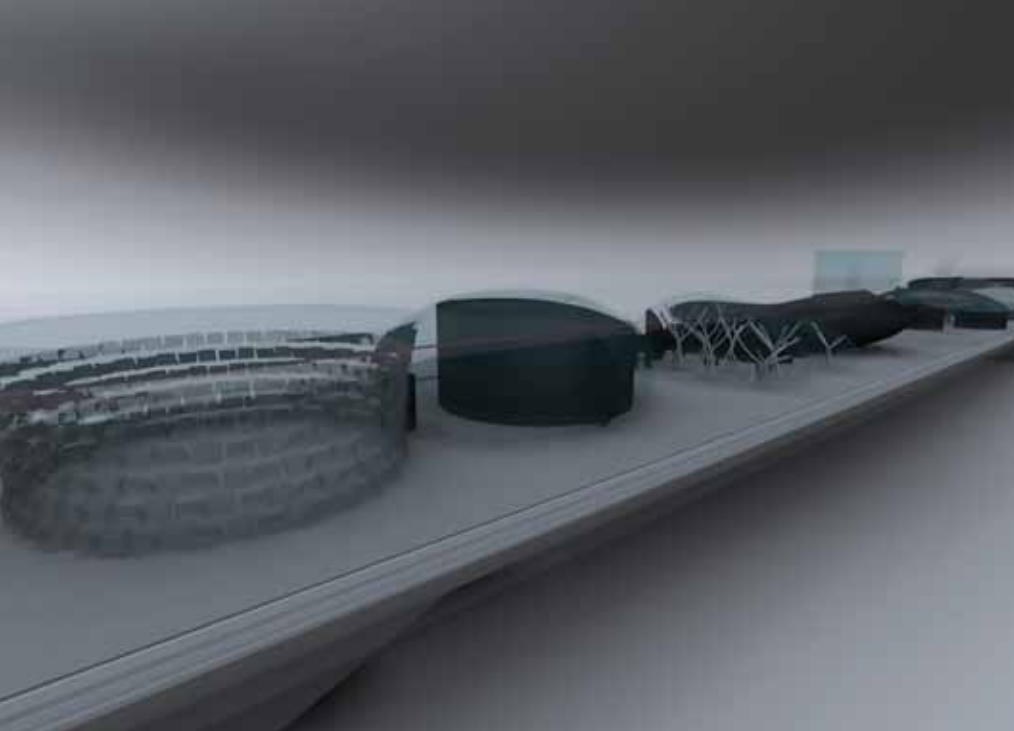



# Museo del AGN Palacio de Lecumberri

Ciudad de México

El diseño original de Lecumberri, en forma de panóptico, puede ser retomando en su dimensión más positiva. Es decir, que las áreas de museo y enseñanza pudieran funcionar como espacios centrales desde donde, en vez de ejercer el control, se articulen transversalmente propuestas museográficas, proyectos culturales, didácticos y de divulgación, y así atender la diversidad de necesidades y demandas.

Algunas de las consideraciones implícitas en estas propuestas tienen que ver con facilitar el acceso a los archivos y el acercamiento a su comprensión, lo cual democratiza la información.

Concurso  
Arquitectura: TEN Arquitectos

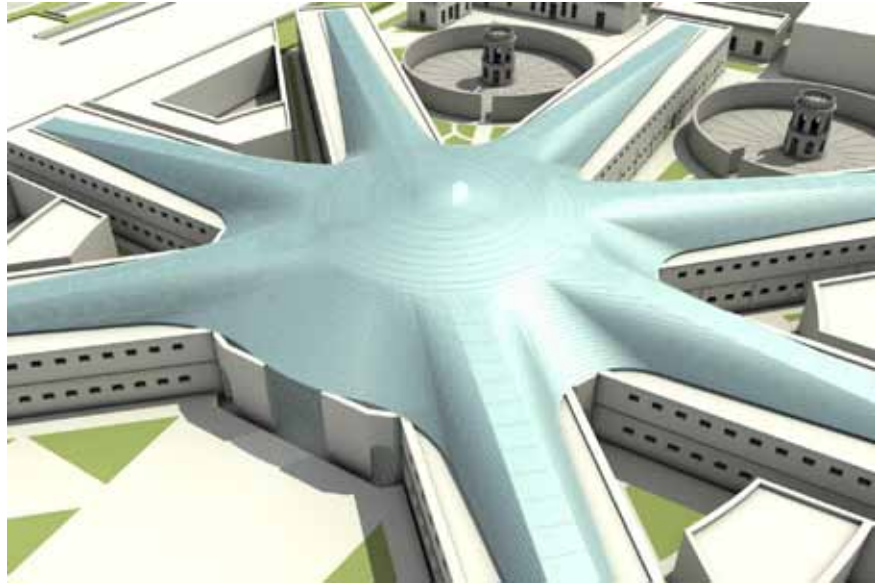



# Museo de Medicina Maya

San Cristóbal de las Casas, Chiapas

Coordinación de gestión, curaduría,  
arquitectura, museografía y paisaje de  
huertos productivos, en colaboración con  
los alumnos del ENCRyM 2,500m<sup>2</sup>



COMPOSICIÓN DE LA PERSONA

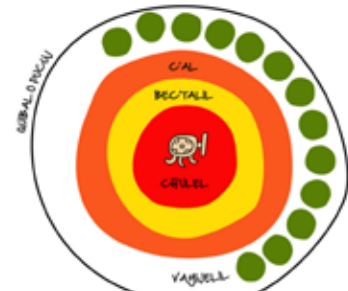

TIPOS DE PERSONA TZOZIL-TZELTAL

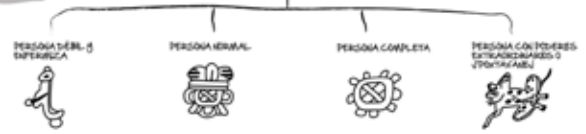

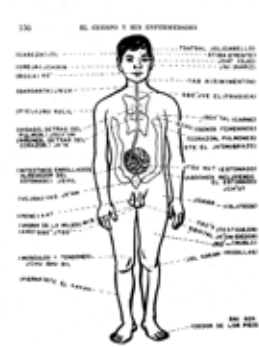
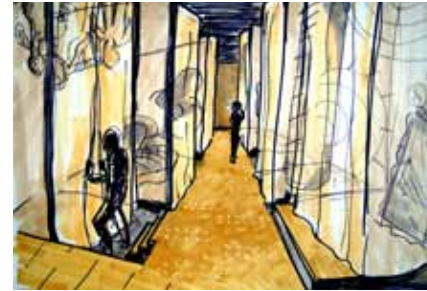

Fig. 11: Concepto de un currículo basado en la fisiología humana.

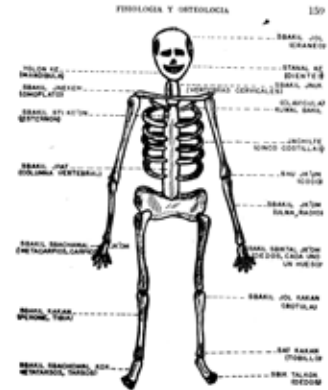

Fig. 12: Concepto de un currículo basado en la fisiología humana.



# Museo del Cine

Cineteca Nacional, Ciudad de México, 2013

Coordinación: Paula Astorga  
Curaduría: Itala Schmelz  
Proyecto para la Cineteca Nacional Siglo XXI



# Museo de Historia Natural

Ciudad de México, 2013

Primer lugar  
Proyecto de remodelación, museografía  
y actualización de contenidos

















BOSQUE DE N

CONFITURA



# Pabellón de México

Bienal de Arquitectura en Venecia, Italia, 2014

Concurso Conaculta

Primer lugar

Investigación: Catherine R. Ettinger

Asesoría: Fernanda Canales

Proyecto ejecutivo: Gaeta y Springall

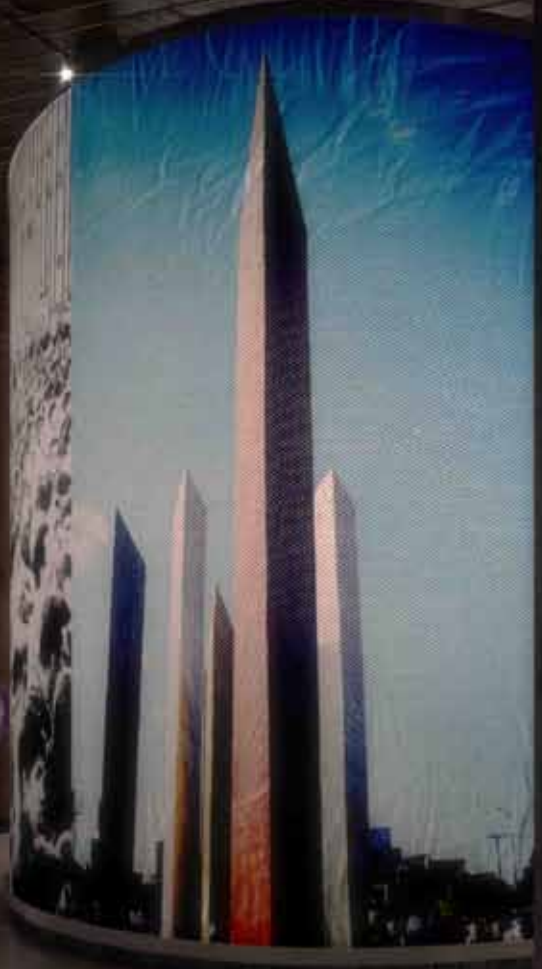

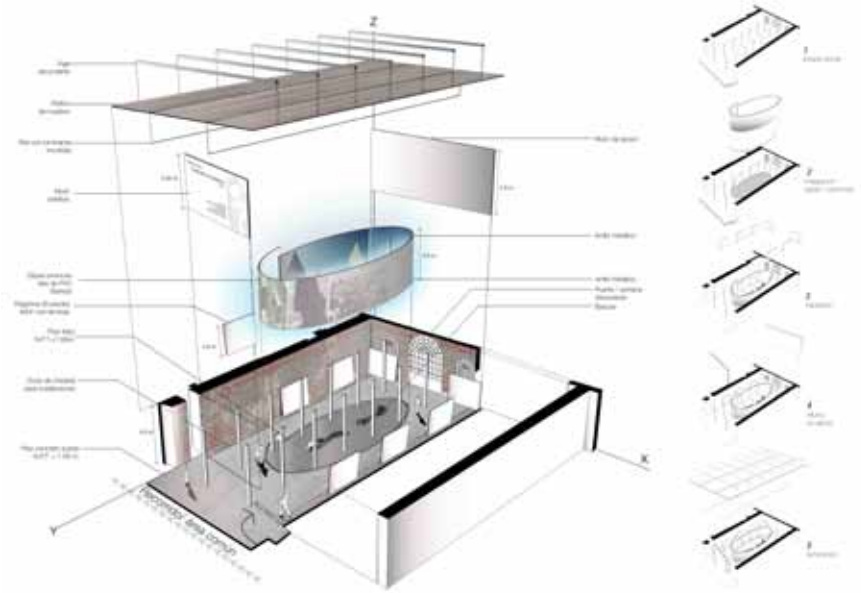

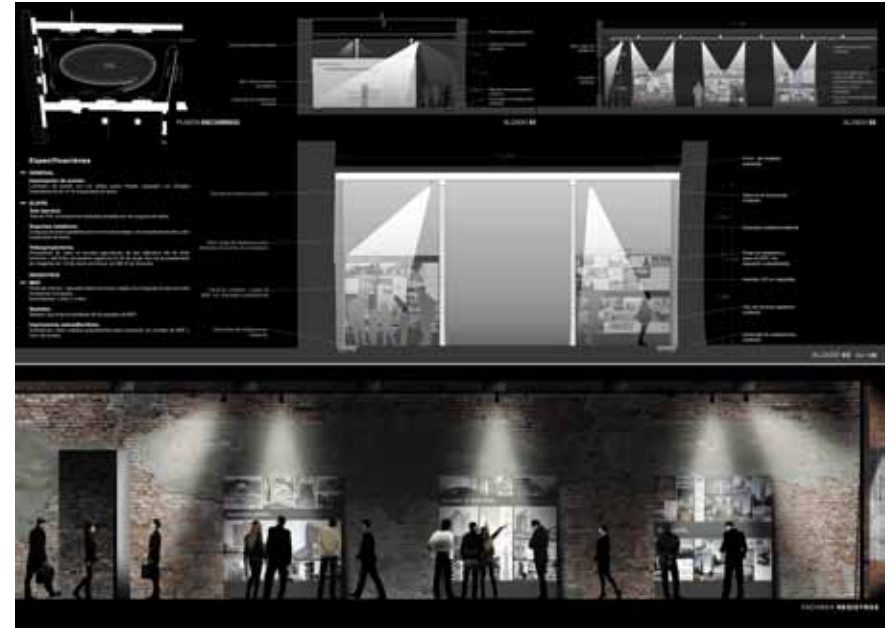
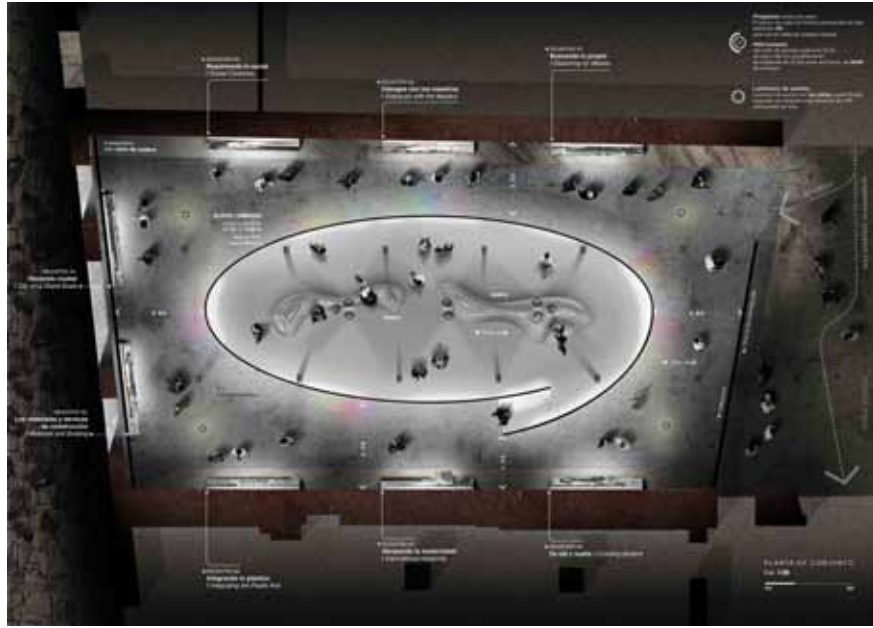





# Lotus, instalación submarina

Océano Índico, Madiha, Matara, Sri Lanka, 2004

Memorial, Sri Lanka

Instalación submarina para la reconstrucción ecológica del mar y como ofrenda a los 35,000 fallecidos por el tsunami

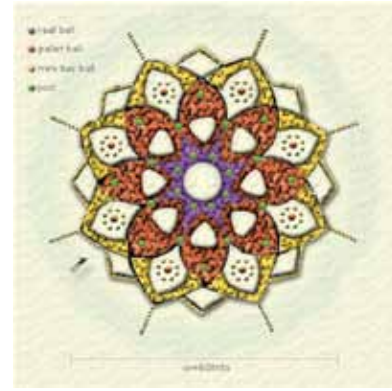
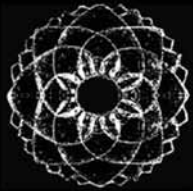

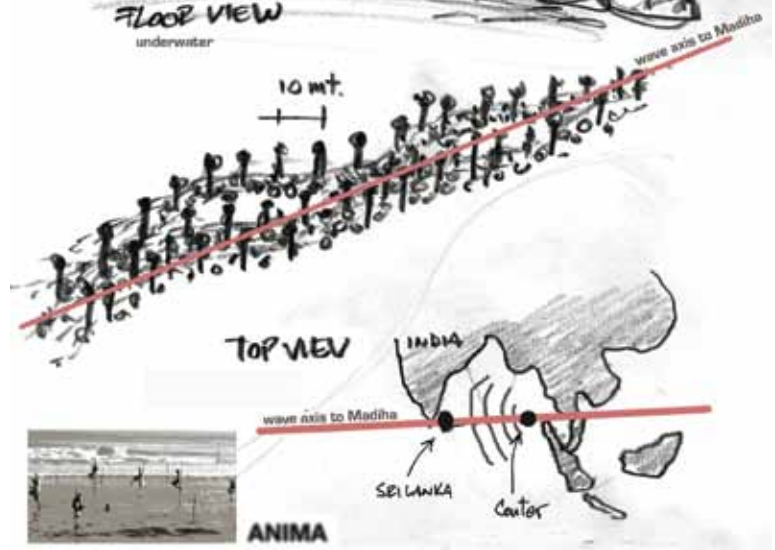

# Pabellón de México

Feria Mundial, Shanghai, China

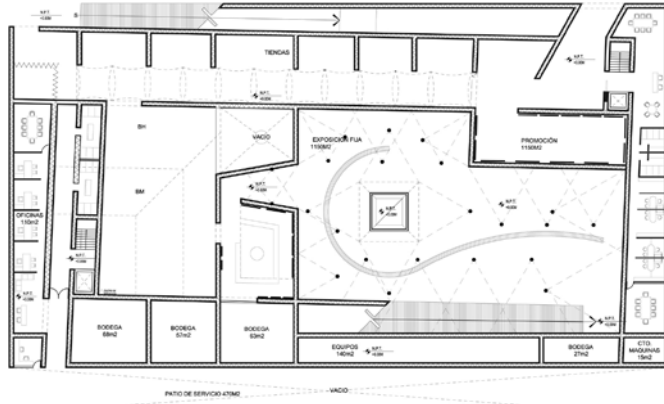

Los bacabob, cuya tarea es sostener el firmamento, son usualmente representados como hombres muy viejos cargando al cielo-dragón. Además, pueden portar una concha o una tortuga.

La tortuga es el vínculo de comunicación entre la tierra y el mar para los mayas, la tierra que flota, los ciclos del tiempo, la sabiduría. BACAB es un arrecife hecho escultura que procura un esfuerzo por rehabilitar el ecosistema marino del caribe mexicano. Un lugar para que visiten buzos y snorkelistas, que reduzca el impacto ambiental del parque de coral, sin olvidar que el mar es el ecosistema más importante del planeta.

The marine friendly structure is working perfectly and is contributing positively to reduce impact to the coral park, and promote fish and coral growth inside the sea's ecosystem.

Escultura de 4 toneladas  
Coordinación: Jason deCaries Taylor

## BACAB, instalación submarina

MUSA Museo subacuático, Cancún, Quintana Roo, 2011

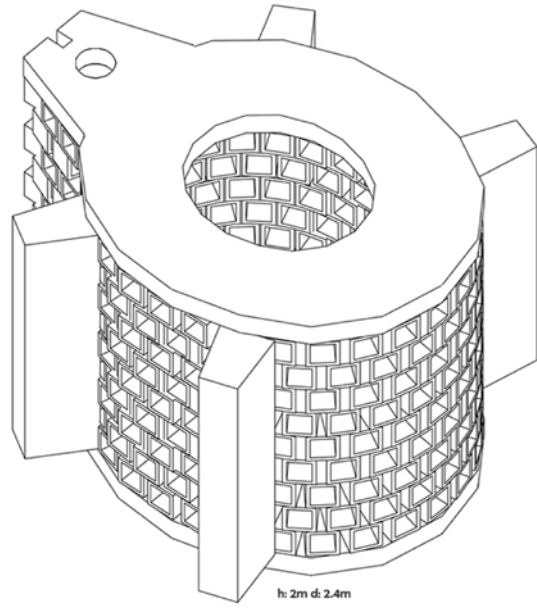

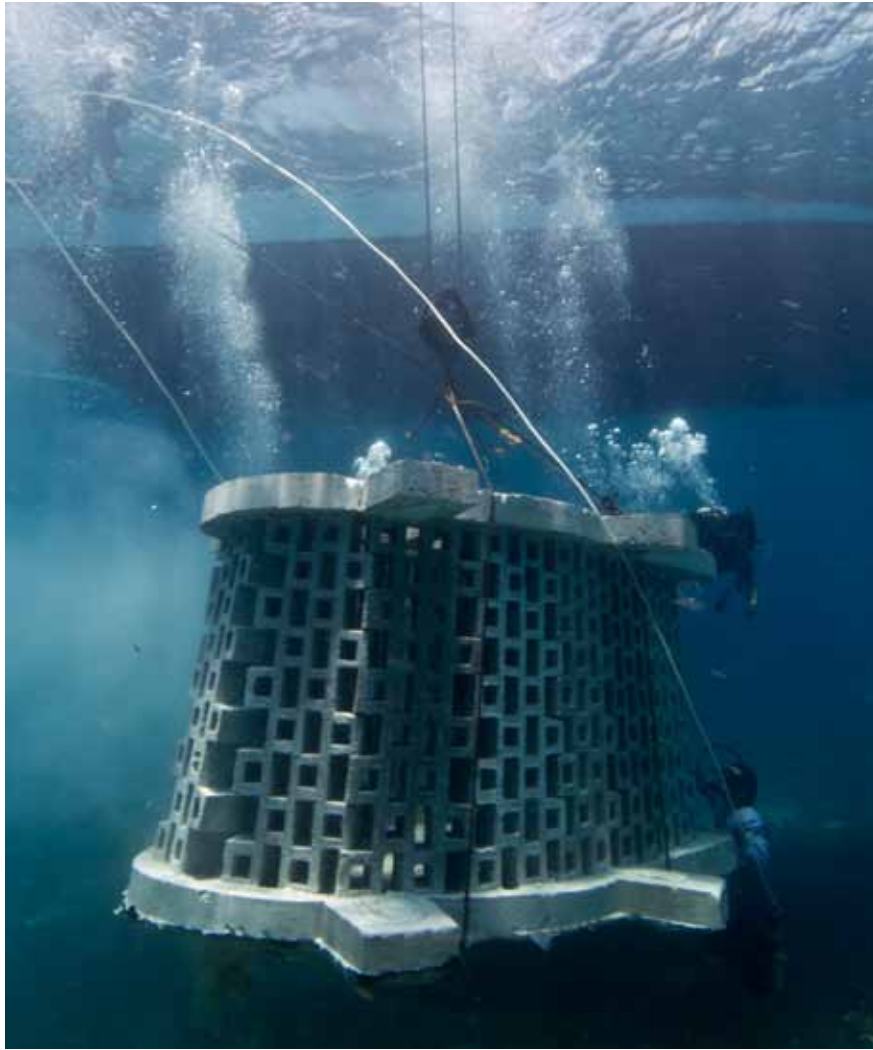





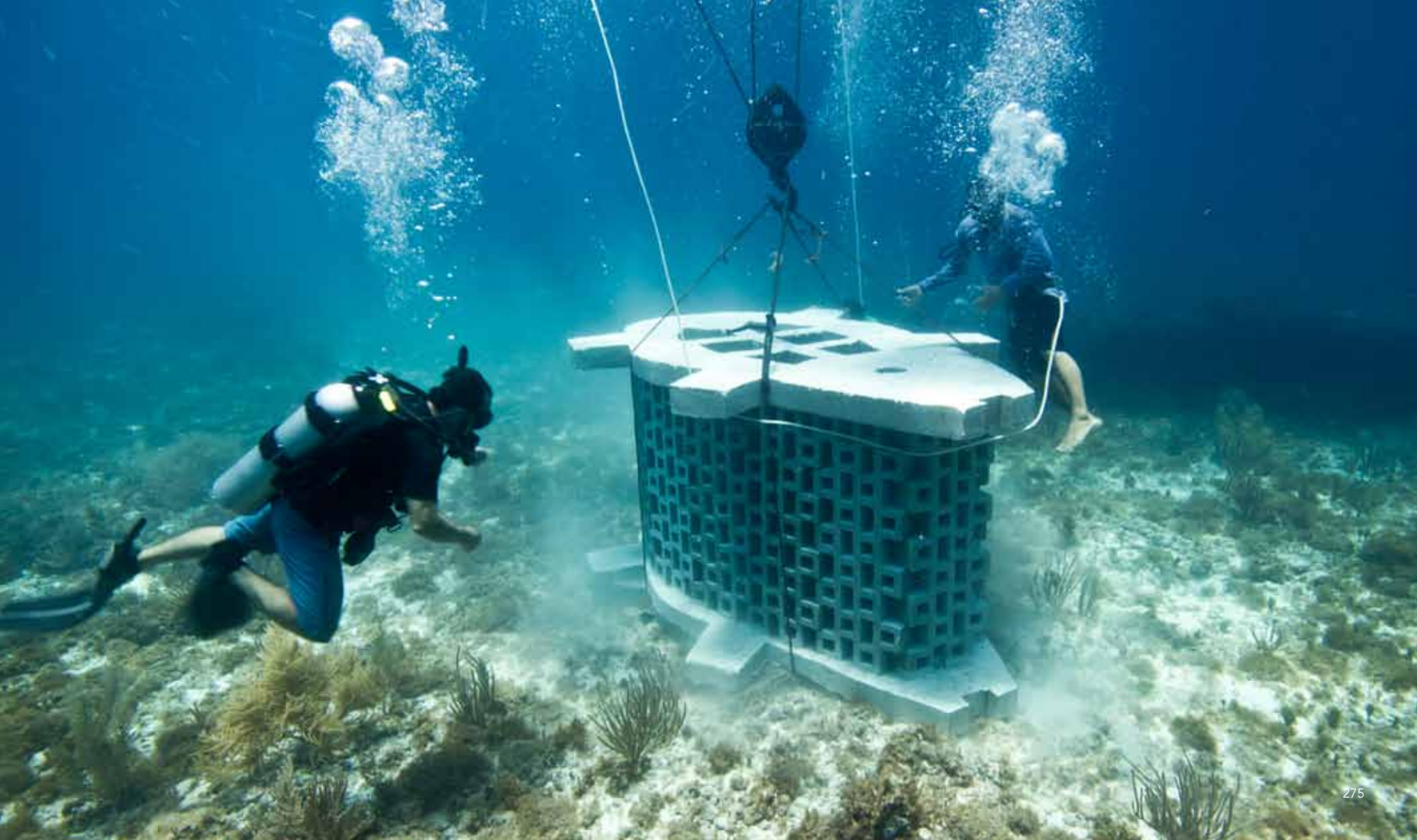



# Movimiento perpetuo

Antiguo Colegio de San Ildefonso, Ciudad de México, 2004

Instalación cinética para la exposición  
Corre caballo corre  
Sistema mecánico y proyectores  
Colaboración: Miguel Rivera  
Colección: Fundación Televisa





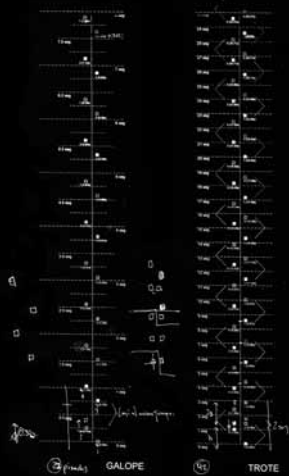

PASO DEL CABALLO

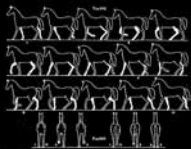

Fig. 10. Paso del caballo. Véase la serie de figuras 1 y 2. Véase también el capítulo 10 del libro de la autora sobre el caballo, con el título de "El caballo y el jinete".



Pituras basadas en los estudios de Maney.

MARCA  
GALOPE

44000 mm

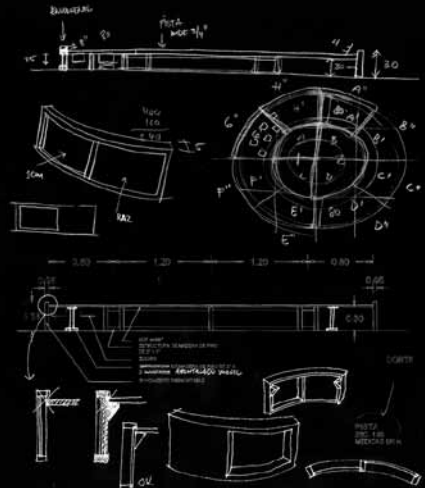

PLANTA-DESPIECE  
1:100  
A.2. Maney

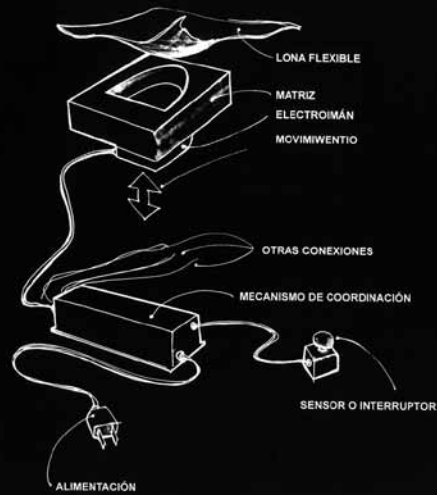
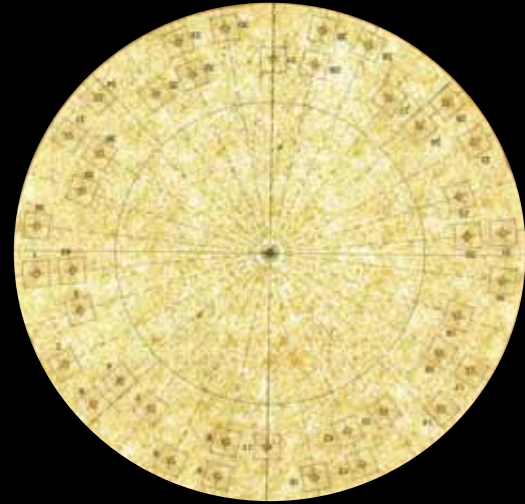
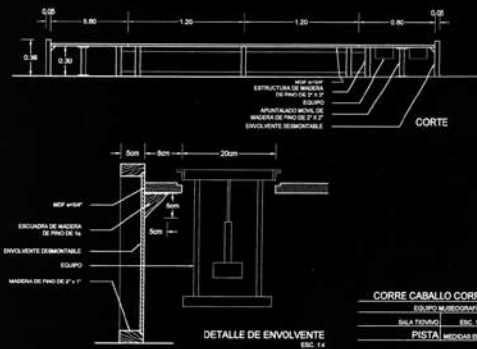



# Catedral del agua

San Juan de la Costa, Mar de Cortés, Baja California Sur, 2012

Proyecto de instalación biológica  
y submarina, propagación de coral,  
ahorro de agua y turismo  
Coordinación: Earth Ocean Farms  
Fotografía: Reef Ball







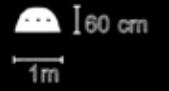
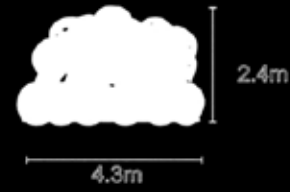
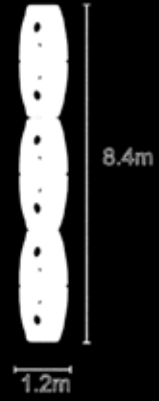
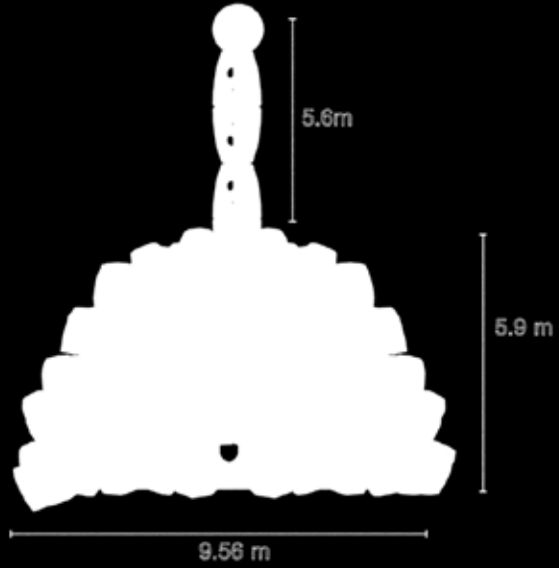

# Candil móvil

Centro Comercial Interlomas, Estado de México, 2012

Esculturas cinéticas realizadas como un nuevo concepto de aprendizaje y contemplación del arte en espacios públicos y comerciales.

Coordinación: GICSA / Marcos Dayan







En sincronización no planeada con los estudiantes del movimiento intelectual y activo que surgió en México para las elecciones presidenciales de 2012, YoSoy132 fue un respiro fallido de esperanza para la renovación ética del país. La instalación creada para un espacio público en el centro comercial Interlomas coincide con 132 hilos conectados a un solo motor cinético y central que hace que una constelación de átomos se mueva armónicamente. Es también mi primera escultura cinética a esta escala.

During the presidential elections of 2012, was a philosophical rise called YoSoy132, a glimps of hope for a better and more ethical country and the beginning of a less corrupt government. Students in the whole country rose together in what seemed to be a rebirth of the ideology and social participation of the college and university community. This kinetic sculpture, is a reminder of this ephemeral movement, an armonic constellation of spheres.

Coordinación: GICSA / Marcos Dayan

## 132 Yo-yo soy

Centro Comercial Interlomas, Estado de México, 2012











proyectos / projects

Cuando Café Tacuba se acercó a Gabriel Báltiz y a mí para realizar este proyecto, contábamos con dos semanas para realizar una escenografía que, no solo debía presentarse en el Teatro Metropolitan la primera vez, sino además formar parte del inicio de un tour de un año por el continente americano. Contando solo con dos cajas del tamaño de un metro cúbico para guardar todos los cables, lámparas, torres ondeables, domos espaciales y demás elementos futuristas que pintarían las nuevas composiciones en el escenario, logramos resolver su equipaje y poner a viajar, visualmente, a millones de seguidores con ellos.

When Café Tacuba approached us for the project, Gabriel Batiz and I had two weeks to present and produce this scenery for a major auditorium called Teatro Metropolitan, of course, in frequency with their new album and the kickoff of a world tour. Packed in two, one cubic meter boxes, we managed to place all the lights, cables, acrylic domes, futuristic towers and translucent fabrics the group needed to paint their contemplative compositions, and to blow the minds of millions of fans.

Diseño de escenografía, concierto REVÉS

## Café Tacvba

Teatro Metropólitan, Ciudad de México, 2002





# Práctica

Línea de computadoras, 2001

Diseño, concepto y anteproyecto  
de computadoras personales fabricadas  
en México

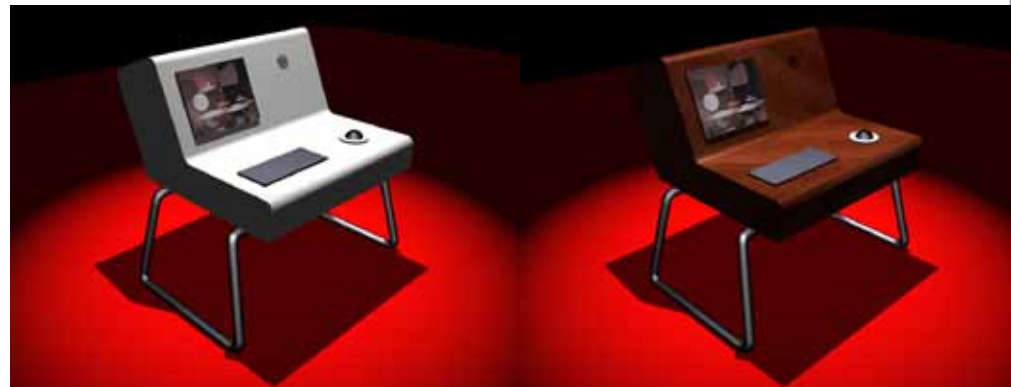
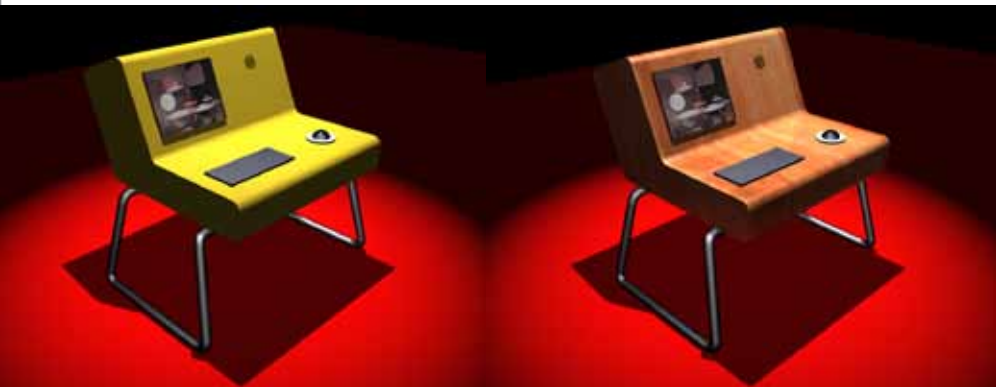

This is what I call learning about something never known before. I must admit that my taboo with sex shops, one I never resolved until this commission started, changed completely. Now.... I definitely recommend that everyone should get into these stores and ask the attendants to walk you around inside (like a museum guide) and explain everything to you. Very very interesting. It is really a subject we should talk about more often.

The project was done in collaboration with Architect Jorge Covarrubias who coordinated the project and invited me to participate, also Maurycy Gomulicky a polish visual artist living in Mexico. The 3 of us did the interiors, the furniture, the logo and the graphics for the store.

Diseño y concepto de sexshop en colaboración con el arquitecto Jorge Covarrubias y Maurycy Gomulicky

# Erotika

Ciudad de México







IN SEARCH FOR A  
MEXICAN IDENTITY, 1992  
Huicholes from the northern  
lands of Nayarit, and a  
homeborn chilango got together  
for coffee.

KEEP IT SAFE, 1992  
Maybe just a box, but inspired in  
ancient Aztec patterns.





First furniture line designed for export, TIZA was trying to confront high-end Mexican hand labor vs. high technological machinery from Europe, also selling in NY. The presentation in ICFF 1998 ( most important furniture exhibit in the US in terms of contemporary design) of 7 different home elements in a new Mexican proposal, had big doubts and insecurities. But the outcome turned out well since we managed to find representation in D&D Building Manhattan, in Merchandise Mart of Chicago, and in Pacific Design Center in L.A.

TIZA is inspired in Mexican crafts and the 90's influences of furniture design in Europe and is still produced today with more elements that form the collection.



TIPICAL HACIENDA, 1993  
Just a vintage approach towards  
the traditional haciendas in  
Mexico and the beautiful  
designs they have



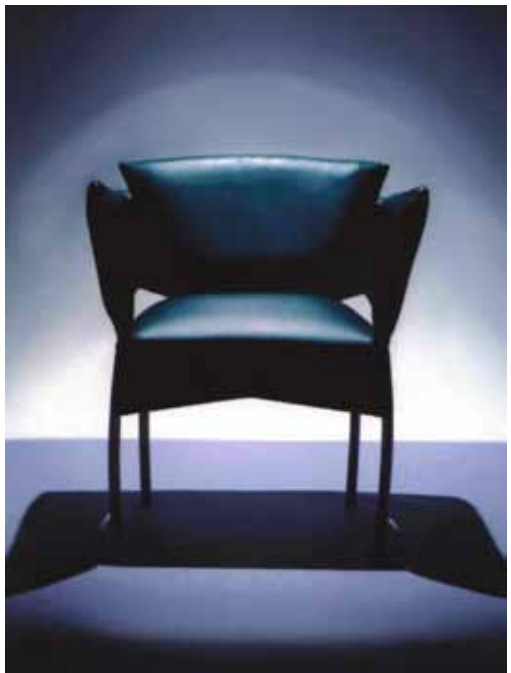

SUPERSONICFEELING,  
1995 to 1998

In the search for a designer identity, and after the early years of cultural influence, in 1995 the process of design made a dramatic turn towards my 60's childhood. And I loved it!!!





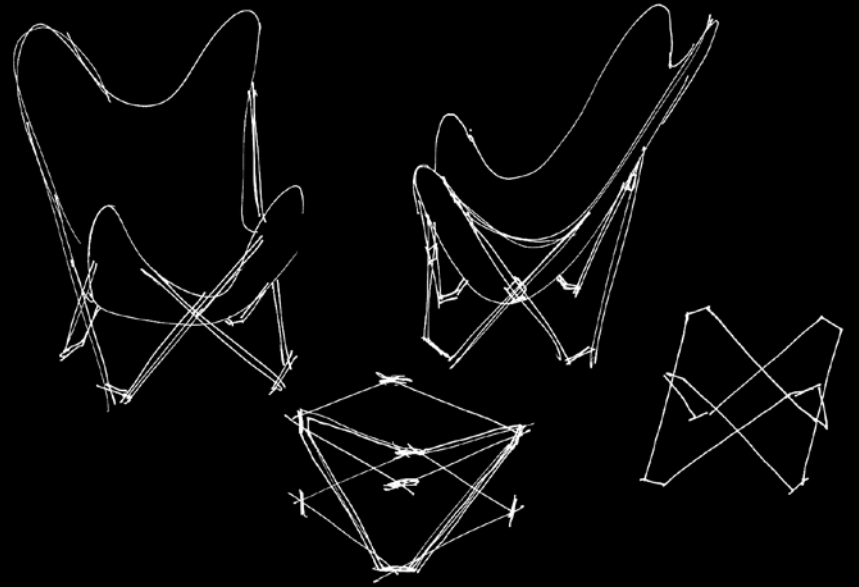
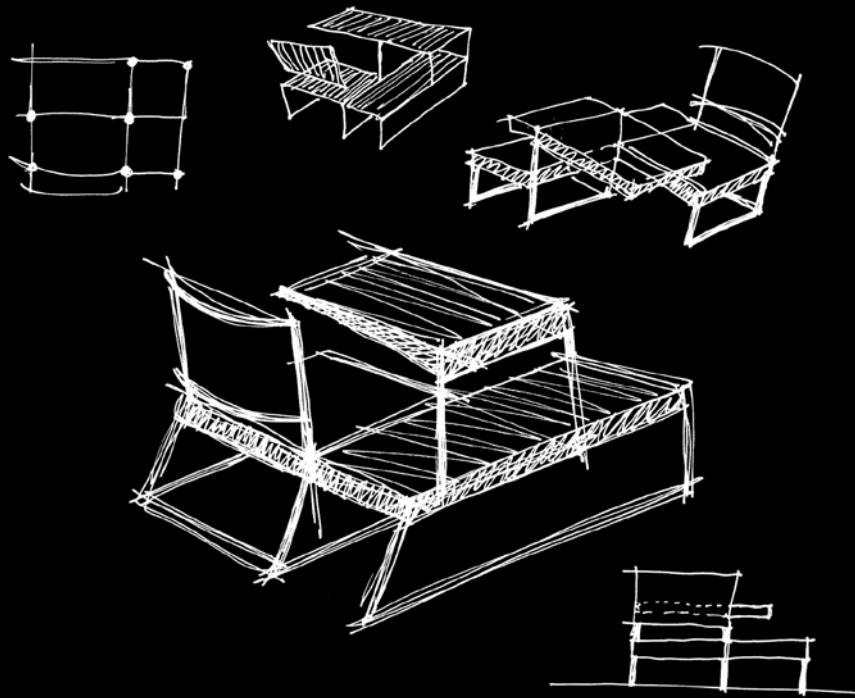

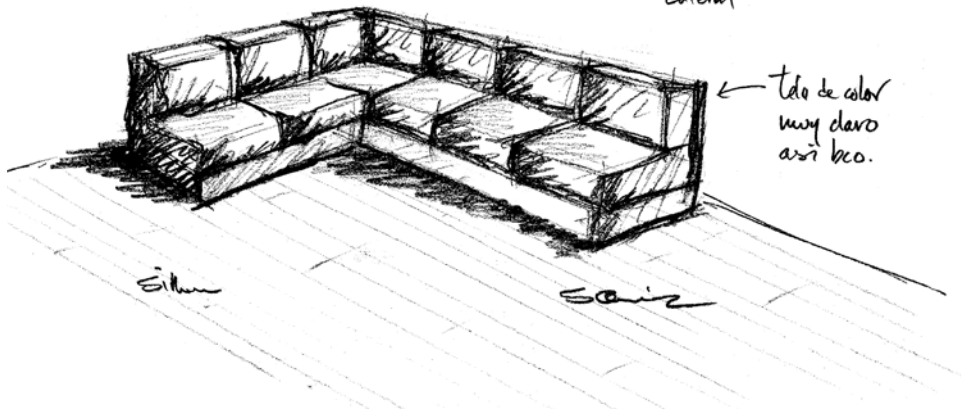
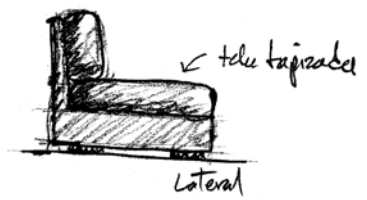

teles de color  
muy claro  
asi bco.

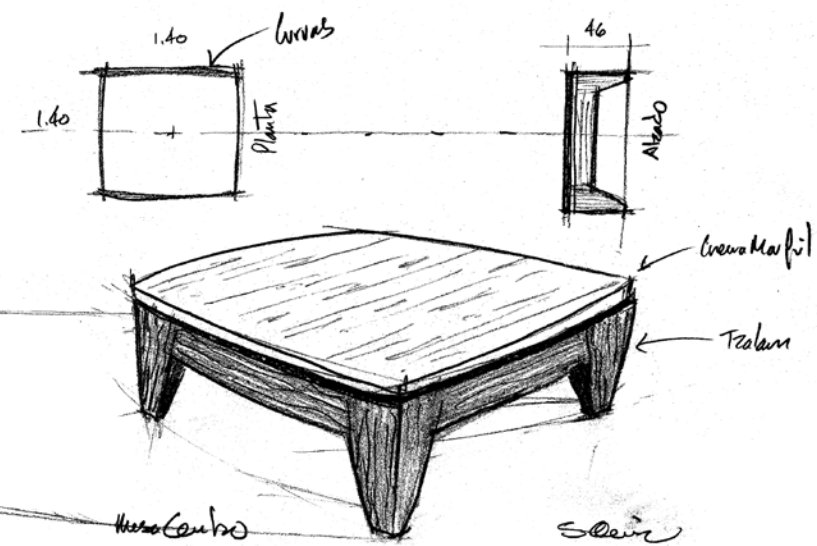

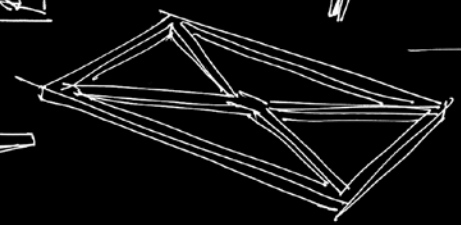
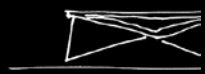
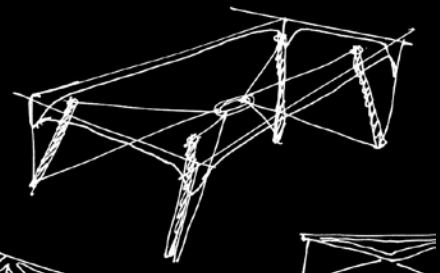
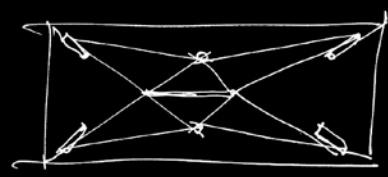
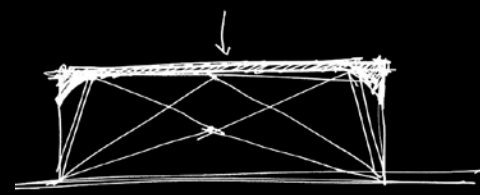
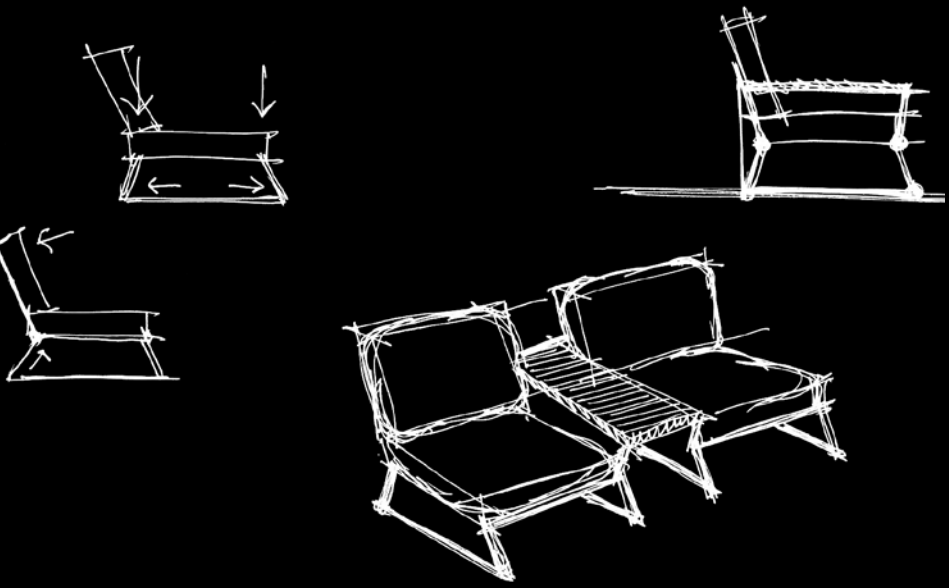



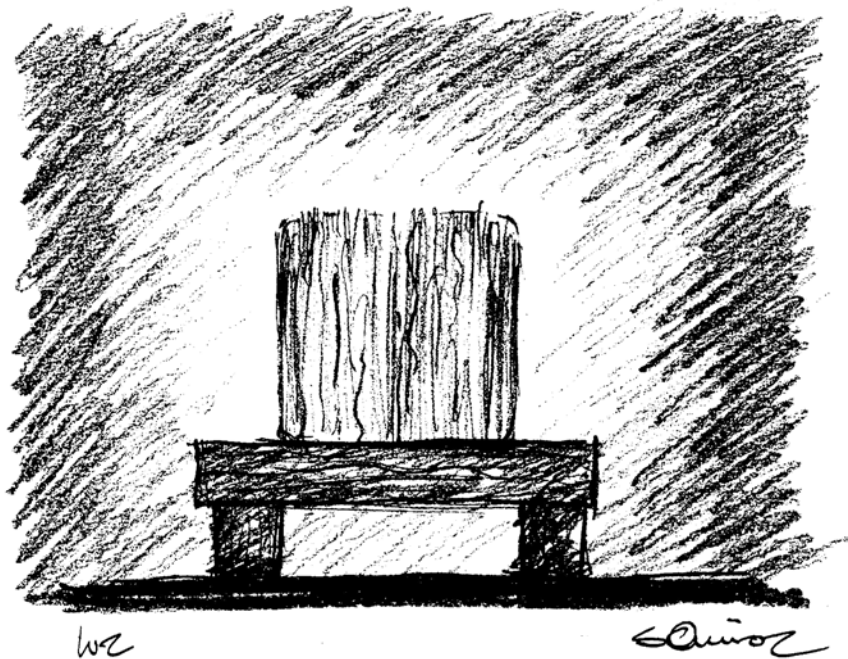
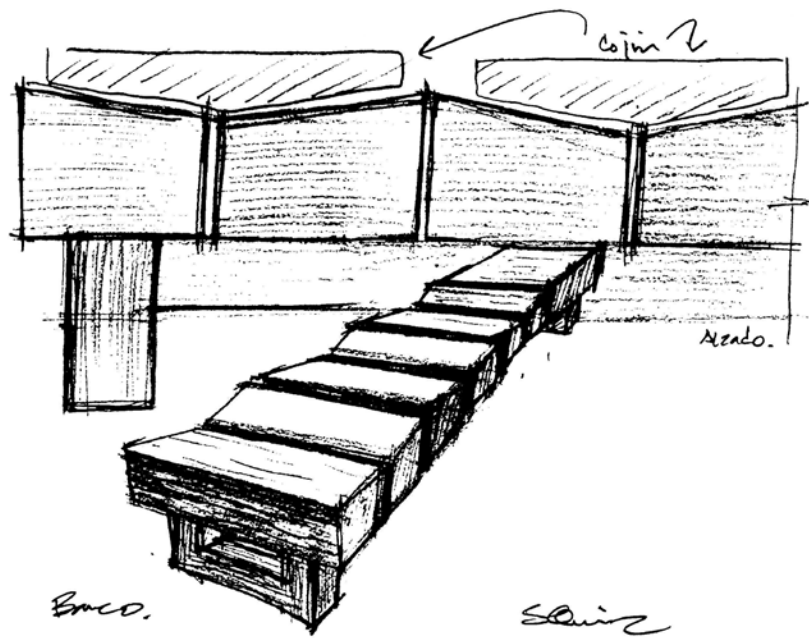

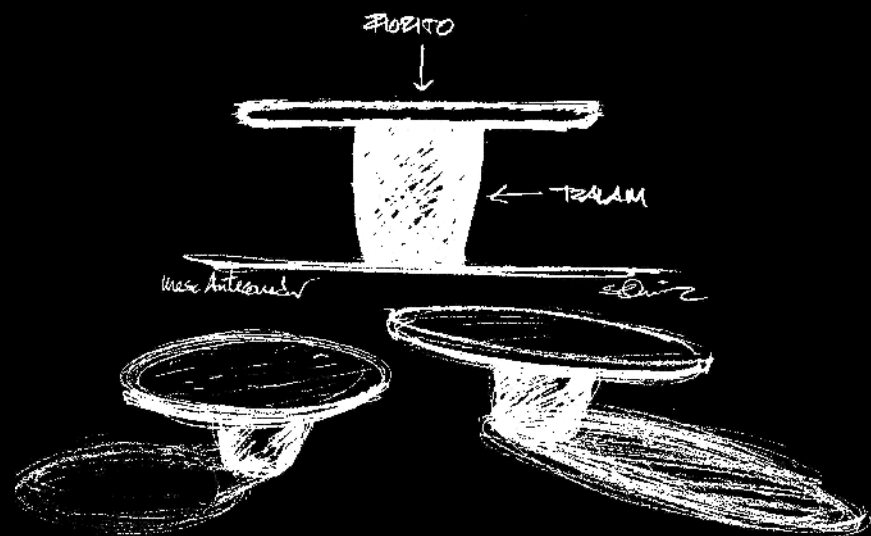
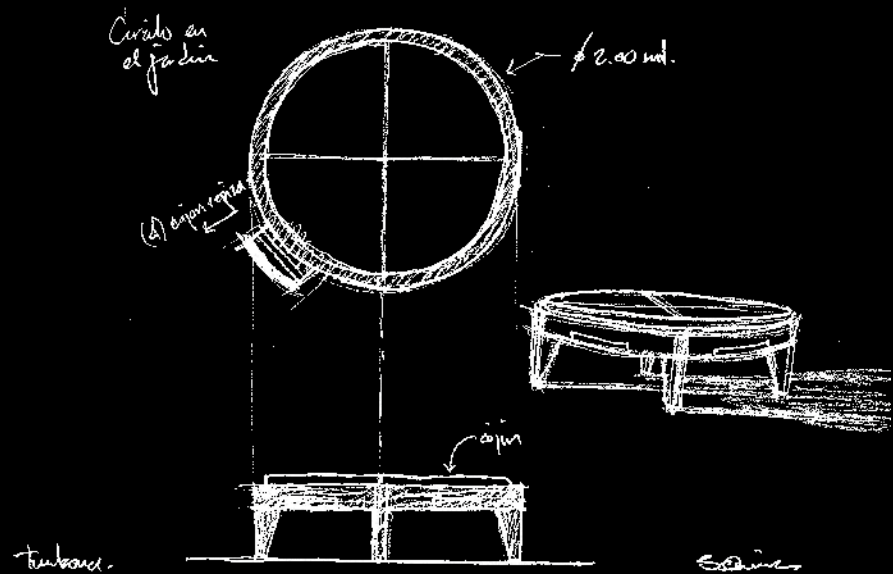

trabajos / work cv

## Museos / Museums

### Museo de Medicina Maya

OMIECH  
Coordinación de gestión,  
curaduría, arquitectura,  
museografía y paisaje de huertos  
productivos, en colaboración  
con el ENCRyM, 2,500m<sup>2</sup>  
San Cristóbal de las Casas,  
Chiapas

### Museo de Cine, Cineteca Nacional

Diseño museográfico de 600 m<sup>2</sup>  
Curaduría: Itala Schmelz  
Coordinación: Paula Astorga  
Proyecto para la Cineteca  
Nacional Siglo XXI  
Ciudad de México, 2013

### Paul Strand, El murmullo de los rostros

Diseño museográfico de 500 m<sup>2</sup>  
Curaduría: Alfonso Morales,  
Héctor Orozco  
Fundación Televisa  
Museo del Palacio  
de Bellas Artes  
Ciudad de México, 2011

### Siquerios paisajista

Diseño museográfico de 600 m<sup>2</sup>  
Curaduría: Itala Schmelz  
Museo de Arte Carrillo Gil  
Ciudad de México, 2011

### La Revolución Mexicana en el espejo de la caricatura estadounidense

Diseño museográfico de 600 m<sup>2</sup>  
Museo de Arte Carrillo Gil  
Curaduría: Juan Manuel  
Aurrecoechea  
Ciudad de México, 2010

### CIEAX Centro de Investigación y Estudios del Agua Xochimilco

Diseño museográfico de  
5,000 m<sup>2</sup>  
Arquitectura: TEN Arquitectos,  
Investigación: Valente Souza  
y Lucy Cruz  
Curaduría: Salvador Quiroz  
Ciudad de México, 2010

### Museo de Sitio del Bosque de Chapultepec

Diseño museográfico de la  
historia del parque más antiguo  
de América Latina.  
Proyectos especiales del DDF  
Ciudad de México, 2009

### Museo de Ciencia y Tecnología, Planetario de Guadalajara

Proyecto con la municipalidad  
Guadalajara, Jalisco, 2009

### Museo de la Biodiversidad Primer lugar (concurso) Pabellón Nacional de las Culturas

Diseño museográfico  
de 3,000 m<sup>2</sup>  
Investigación: Dr. Exequiel  
Ezcurra; Arquitectura: Serrano  
Monjaraz Arquitectos  
Cabo San Lucas, Baja California  
Sur, 2008

### Exposición Retrospectiva de Gabriel Figueroa Cinematógrafo

Curaduría: Alfonso Morales y la  
Colección Filmica de Televisa

Museo del Palacio  
de Bellas Artes  
Ciudad de México, 2007

Parque Fundidora  
Monterrey, Nuevo León,  
2008-2009

CECUT Centro Cultural Tijuana  
Tijuana, Baja California, 2009

MAZ Museo de Arte de Zapopan  
Guadalajara, Jalisco, 2010

Festival de Fotografía  
Arles, Francia, 2011

LACMA  
Los Ángeles California, 2011

### Exposición Abel Quezada

Curaduría: Alfonso Morales  
Retrospectiva del autor.  
Museo de la Ciudad de México,  
2011

Rejas de Chapultepec  
Ciudad de México, 2009

### Exposición Eternidad Fugitiva

Colección fotográfica hecha  
por Manuel Álvarez Bravo  
Fundación Televisa  
Curaduría: Alfonso Morales

Museo del Palacio  
de Bellas Artes  
Ciudad de México, 2004

Museo MARCO  
Monterrey, Nuevo León, 2005

**Exposición Corre Caballo Corre**  
Curaduría: Alfonso Morales  
sobre la colección fotográfica  
de Televisa  
Antiguo Colegio de San  
Ildefonso  
Ciudad de México, 2004

**Instalación Fundación Televisa**  
Muestra 2 World Trade Center,  
Ciudad de México, 2003

**World Fair, Hannover**  
**Pabellón de México**  
Sala 6 "Construcción futura"  
instalación de fibra óptica,  
video y audio  
Hannover, Alemania, 2000

**Europalia**  
**Entre el arte y la industria**  
Primera exposición de diseño  
contemporáneo mexicano en  
europa  
Bruselas, Bélgica, 1993

**Europalia**  
**El color en la arquitectura**  
Exposición fotográfica del  
Colegio de Arquitectos de  
México  
Bruselas, Bélgica, 1993  
París, Francia, 1993

**Arte e instalación / Art &  
Installations**

**Catedral del agua**  
Proyecto de instalación biológica  
y submarina, propagación de  
coral, ahorro de agua y turismo  
Coordinación:  
Earth Ocean Farms  
Mar de Cortés, San Juan de la  
Costa, Baja California Sur, 2012

**Candil coreográfico**  
**132 Yo-yo soy**  
Esculturas cinéticas con  
motorización y sistema Arduino  
instalación en GICSA espacio  
comercial y privado  
Coordinador: Marcos Dayan  
Ciudad de México, 2012

**BACAB escultura submarina**  
Pieza de 4 toneladas para  
restauración de coral y  
propagación de peces  
Coordinación:  
Jason deCaries Taylor  
MUSA Museo Subacuático  
Cancún, Quintana Roo, 2011

**Instalación para Gabriel**  
**Figueroa Cinematógrafo**  
Instalación de pieza *El Misterio*  
de Traven  
Lugar, 2008

**Memorial, Sri Lanka**  
Instalación submarina para la  
reconstrucción ecológica del  
mar y como ofrenda a los 35,000  
fallecidos por el tsunami  
Madiha, Matara Sri Lanka, 2004

**Pabellón de la tortilla**  
La Granja México  
Hipódromo de las Américas  
Ciudad de México, 2004

**Instalaciones para Corre**  
**Caballo Corre**  
- Movimiento perpetuo  
- Óvalo de Sotelo  
- Tío vivo  
Antiguo Colegio de San  
Ildefonso  
Ciudad de México, 2004

**ABCDP**  
- Instalación de audio *Tiendas*  
*ambulantes*  
- Instalación de audio *La traigo*  
*muerta*  
Mobiliario interactivo  
Palacio de Bellas Artes  
Ciudad de México, 2002

**Casa, vestido y sustento**  
Instalación Luz en el colado  
Ex Teresa Arte Actual, colectivo,  
Ciudad de México, 2002

**UNICEF**  
Muebles arte objeto  
World Trade Center  
Ciudad de México, 1995

**Galería Mexicana de Diseño**  
Exposición colectiva  
Muebles arte objeto  
Ciudad de México, 1994

**Galería Galileo 100**  
Exposición colectiva  
Muebles arte objeto  
Ciudad de México, 1994

**Europalia**  
**Entre el arte y la industria**  
Instalación de muebles  
contemporáneos  
Bruselas, Bélgica, 1993

**Proyectos de Arquitectura /  
Architectural Projects**

**Proyecto Casa Pereyra**  
Conceptual, ejecutivo y  
supervisión de obra  
Colaboración: Diana Quiroz  
Lomas de Chapultepec  
Ciudad de México, 2008- 2009

**Parque San Antonio**  
Plan Urbano y Equipamiento  
con Consejo Terrícola A.C.  
Colaboración: Arq. Axel Arañó  
Valle de Bravo, Estado de  
México, 2007

**Hotel B&B Coyoacán**  
600 m<sup>2</sup>  
22 recámaras  
Ciudad de México, 2007

**Edificio de departamentos**  
Colima, Colonia Roma  
Colaboración: Arq. Axel Arañó  
Ciudad de México, fecha

**Casa Sosa**  
300 m<sup>2</sup> terreno y 250 m<sup>2</sup>  
construidos  
Coyoacán, Ciudad de México,  
2007

**Centro de Buceo y**  
**Educación del Mar**  
Proyecto, financiamiento  
y concepción  
Madiha Distrito de Matara,  
Sri Lanka, 2006

**Espacio REDES**  
Centro de talleres de arte y  
cultura para la merced  
Fundación Televisa  
Centro histórico, Ciudad de  
México, 2004

**Desarrollo urbano de**  
**Playa Larga**  
Plan maestro de mercado,  
embarcadero, ciclista y  
parque ecológico  
Colaboración: Arq. Mauricio  
Rocha y Arq. Arturo Mera  
Ixtapa, Zihuatanejo, Guerrero,  
fecha

**FONATUR**  
**Concurso Biblioteca Nacional**  
**de la Ciudad de México**  
8vo. lugar Internacional  
México, 2004

**Casa Sumiya**  
Desarrollo de detalle y  
equipamiento arquitectónico  
Cuernavaca, Morelos, México,  
2003

**Discoteca Colmillo**  
Iluminación, mobiliario y arte,  
Ciudad de México, 2002

**Vitalia**  
Tiendas dermatológicas  
San Jerónimo y Plaza Satélite  
Ciudad de México, 2002

**Casa Visoso**  
Proyecto completo 500 m<sup>2</sup>  
Ciudad de México, 2002

**Qualton Hoteles**  
Tres proyectos de 20  
habitaciones de lujo  
Ciudad de México, 2002

**Bar y restaurante Kubo**  
Zona Rosa  
Ciudad de México, 2000

**Equipamiento departamentos**  
**Roma**  
Colaboración con Laboratorio  
de la Ciudad de México, 2001

**Centro de desarrollo para**  
**invidentes y débiles visuales**  
8,000 m<sup>2</sup>  
Gobierno de la Ciudad  
Medalla de Plata  
Bienal de Arquitectura  
Ciudad de México, 2001

**Oficinas corporativas MEXUS**  
PH Ciudad de México, 2001

**Bar y restaurante E2**  
Interiores, audio, video  
y arquitectura  
Zona Rosa  
Ciudad de México, 2000

**Oficinas corporativas de The**  
**Attik Design & Broadcasting**  
Proyecto interior y manufactura  
San Francisco, EUA, 2000

**Residencial**  
Proyectos interiores  
Chicago, EUA, 1999

## METRO

### bar, sala de conciertos y restaurante

Interiores, audio, video y arquitectura  
Zona Rosa  
Ciudad de México, 2000

### La Vaca Independiente

Remodelación de hacienda antigua e interiores para oficinas  
Anzures, Ciudad de México, 1996

### Restaurante Toscana

Equipamiento mobiliario,  
Ciudad de México, 1996

### Restaurante Cibernet

Equipamiento mobiliario  
San Ángel  
Ciudad de México, 1996

### Revista Sacbé

Equipamiento mobiliario  
Roma, Ciudad de México, 1995

### Palacio de Bellas Artes Tienda

Centro, Ciudad de México, 1994

### Museo Nacional de Arte Tienda

Centro, Ciudad de México, 1994

### La Vaca Independiente

mobiliario  
Condesa, Ciudad de México, 1994

### Telecomunicaciones de México

mobiliario  
Ciudad de México, 1992

## Sigrosa

Oficina Corporativa Lomas,  
Ciudad de México, 1992

## Soloflex

Oficina Corporativa  
Guadalupe Inn, Ciudad de México, 1991

## Proyectos de diseño y mobiliario / Furniture Design

### Colección de mobiliario

Diseño de 200 piezas diferentes en mobiliario trabajadas desde 1993-2008

### Escenografía REVES de Café Tacvba

Teatro Metropolitan  
Ciudad de México, 2002

### Línea TIZA

Mobiliario  
Presentación en ICFF  
Nueva York, 1998

### Bagno? o sono desto

Concurso internacional  
Mobiliario  
Italia, 2001

### Línea de computadoras Praktica

Diseño, concepto y anteproyecto de computadoras personales fabricadas en México, 2001

## Desarrollo Villa de Guadalupe

Mobiliario urbano,  
Fideicomiso Villa de Guadalupe  
Delegación Gustavo A. Madero  
Departamento del Distrito Federal, 1997

## Exposiciones sector comercial / Exhibitions and Fairs

### FONATUR

Imagen Internacional MIPIM  
Construcción Saluzzo Italia,  
montaje Cannes, Francia, 2001

### Concurso Nacional del Pabellón de México en el Ámbito Turístico

Primer Lugar  
Secretaría de Turismo, 1996

### MVS, Multivisión & Direct TV México

Dirección General, 1990-1995

### Harinera La Espiga

Feria del Pan  
Ciudad de México, 1994

### Gobierno del Estado de Chiapas

Presentación Europalia México  
1993  
Bruselas, Bélgica, 1993

### Gobierno del Estado de México

Presentación Europalia México  
1993  
Bruselas, Bélgica, 1993

## Bridgestone Firestone

Autoshow  
Guadalajara, Jalisco, 1993

## SCT, Pabellón de México

2500 m<sup>2</sup> Americas Telecom,  
Secretaría de Comunicaciones y Transportes  
Acapulco, Guerrero, 1992

## Telecomunicaciones de México

Programa de exposiciones  
Sistemas Satélite Solidaridad,  
1991-1992

## FUJI

### Fotografía y Artes Gráficas

Programa de exhibiciones  
Dirección General, 1991-1993

### General Tire / Continental

Programa de exhibiciones  
Dirección de Mercadotecnia,  
1991-1993

### Expo-Centenario

Secretaría de Comunicaciones y Transportes  
Ciudad de México, 1991

## PROFECO

### Procuraduría del Consumidor

Feria del Hogar  
Palacio de los Deportes  
Ciudad de México, 1990

### La Ciudad de México desde su fundación hasta el año 2000

DDF, Departamento del Distrito Federal  
Zócalo, Ciudad de México, 1990

## Publicaciones / Reviews

### Financial Times de India

2006

### Periódico Sri Lanka Journal

2006

### Revista Arquine

marzo, 2004

### Revista Quattro

entrevista, 2003

### Periódico Reforma

entrevista y video

### PRAXIS

Nueva York, 2001

### Casas y Gente

México, 2000

### DDN Design Diffusion News

Italia, 1999

### Wallpaper Magazine

Inglaterra, 1998

### Harpers Bazar

México, 1998

### Chicago tribune

Estados Unidos, 1999

### HomoFaber catálogo de arte y diseño

México, 1995

## Premios / Awards

### Primer Lugar

### Concurso Museo de la Biodiversidad

Cabo San Lucas, México  
Colaboración con Serrano Arquitectos, 2008

### Mención honorífica

### BRAUN Alemania

Por la coordinación del proyecto Sonidos y producto lap-Bass-guitar, con alumnos de la Universidad Iberoamericana, 2004

### Primer Lugar

### Concurso Sala del Futuro

Pabellón de México en Hannover, Alemania  
Guión: Enrique Krauze  
Arquitecto: Ricardo Legorreta, 2000

### Primer lugar

### Concurso Podio Presidencial

Presidencia de la República, 2000

### Medalla de Plata

### Bienal de Arquitectura

Diseño interior en Colaboración con Mauricio Rocha, 2002

### Primer Lugar

### Concurso Pabellón FONATUR

Muestra Europa Francia, 2001

### Mención Honorífica

### Concurso de Mobiliario Urbano

Ciudad de México, 2001

conceptom

Salvador Quiroz

Río Balsas 37-C, col Cuauhtémoc

México, D.F. 06500

(55) 5615 4659

(55) 5533 8952

salvador@conceptomuseos.com